

# Leica MC1

## Machine control software Excavator

### User manual (UM)

Software version: 7.2

Manual version: 8.0  
Released: 24/02/2026

Language: English (EN)

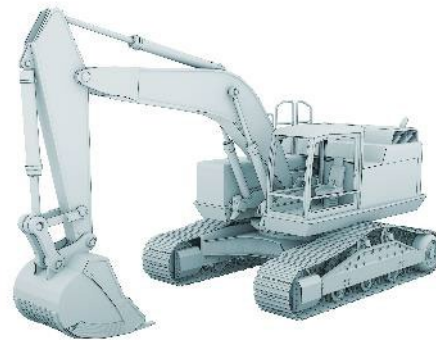

Manual type: User manual (UM).

ID: 950050

Manual version: 8.0

Released: 24/02/2026

Made by: LSIF

Content: User workflows relating to the Leica MC1 machine control software for excavators.

Software: Leica MC1.

Software version: 7.2

Machine type: Excavator.

Brand: All.

Model: All.

Limitations: All rights reserved. No part of this manual may be reproduced in any form, or by any means, without prior written permission from LMC support.

Support: LMC support:

- Mail: \_\_\_\_\_
- Phone: \_\_\_\_\_

# Table of contents

<b>Introduction</b> .....	<b>4</b>
<b>1. Solution</b> .....	<b>5</b>
Workflow 1.1. Find out what solution you have (2D or 3D?) .....	6
<b>2. System</b> .....	<b>8</b>
Workflow 2.1. Change units (2D/3D) .....	9
Workflow 2.2. Switch from 3D to 2D mode (2D/3D) .....	10
Workflow 2.3. Use the MC1 on-screen help (2D/3D) .....	11
<b>3. Run-screen indicators</b> .....	<b>13</b>
Workflow 3.1. Activate tilt indicator (2D/3D) .....	14
Workflow 3.2. Change indicators at top of run-screen (2D/3D) .....	15
<b>4. Bucket</b> .....	<b>18</b>
Workflow 4.1. Create a new bucket (2D/3D) .....	19
Workflow 4.2. Re-calibrate a bucket (2D/3D) .....	23
Workflow 4.3. Verify a bucket calibration (2D/3D) .....	24
Workflow 4.4. Change bucket (2D/3D) .....	25
Workflow 4.5. Change height tool point (2D/3D) .....	26
Workflow 4.6. Select "closest to" tool point (2D/3D) .....	27
Workflow 4.7. Change side tool point (2D/3D) .....	28
Workflow 4.8. Set direction of X (2D) .....	29
Workflow 4.9. Bench bucket height (2D) .....	31
Workflow 4.10. Offset benched bucket height (2D) .....	32
Workflow 4.11. Set bucket slope values (2D) .....	33
Workflow 4.12. Use moving point (load/store), (2D) .....	35
<b>5. Laser</b> .....	<b>36</b>
Workflow 5.1. Set up your laser (2D) .....	37
Workflow 5.2. Bench laser height (2D) .....	38
Workflow 5.3. Offset benched laser height (2D) .....	40
Workflow 5.4. Align slope values of laser and bucket (2D) .....	41
<b>6. Tolerances</b> .....	<b>42</b>
Workflow 6.1. Change tolerance colours (2D/3D) .....	43
Workflow 6.2. Change tolerances (2D/3D) .....	44
Workflow 6.3. Change tolerance "beep volume" (2D/3D) .....	45

<b>7. Auto mode</b>		<b>48</b>
Workflow 7.1.	Engage CoPilot auto tilt (2D/3D)	49
Workflow 7.2.	Engage CoPilot auto rotator (2D/3D)	51
Workflow 7.3.	Engage semi-automatic machine control (2D/3D)	53
<b>8. Projects and models</b>		<b>55</b>
Workflow 8.1.	Synchronize files (3D)	56
Workflow 8.2.	Find your project and models (3D)	57
Workflow 8.3.	Select and use references from run-screen (3D)	59
Workflow 8.4.	Create a baseline model (3D)	61
Workflow 8.5.	Create a dual slope model (3D)	65
<b>9. References</b>		<b>68</b>
Workflow 9.1.	Select and use a height reference (3D)	69
Workflow 9.2.	Select and use a side reference (3D)	70
Workflow 9.3.	Offset a model reference (3D)	71
Workflow 9.4.	Offset individual references (3D)	72
<b>10. As-built</b>		<b>74</b>
Workflow 10.1.	Create point logs (3D)	75
<b>11. TPS</b>		<b>76</b>
Workflow 11.1.	Set up your TPS (3D)	77
Workflow 11.2.	Confirm your machine control license (Captive), (3D)	78
Workflow 11.3.	Confirm your machine control license (iCON Site), (3D)	79
Workflow 11.4.	Prepare your TPS for connection to MC1 (3D)	80
Workflow 11.5.	Connect your TPS to MC1 (3D)	81
Workflow 11.6.	Work with a single TPS (3D)	84
Workflow 11.7.	Work with dual TPS (3D)	86
Workflow 11.8.	Use prism search to re-connect a TPS (3D)	87
Workflow 11.9.	Perform daily machine check-in (TPS), (3D)	88
Workflow 11.10.	View machine position (Captive), (3D)	89
Workflow 11.11.	View machine position (iCON Site), (3D)	90
<b>12. GNSS</b>		<b>91</b>
Workflow 12.1.	Select GNSS positioning profile (3D)	92
Workflow 12.2.	Perform daily machine check-in (GNSS), (3D)	93
Workflow 12.3.	Perform "GNSS elevation of known point" (3D)	94

# Introduction

In this user manual (UM) you will find essential workflows to help you gain success with your machine control solution.

All workflows evolve around Leica MC1 machine control software for **excavator**. MC1 is used on the MCP80 control panel.

Every workflow begins with a short explanation of the task you may be facing, followed by a step by step procedure to help you finish your task successfully.

If you want to dive deeper into the functionality of the MC1 and your machine control solution, you can find a lot of information and guidance in the "how to" videos created for training purposes, and in the User Reference Manual (URM) for excavator.

# 1. Solution

Begin your user experience by finding out what type of solution you have installed on your machine.

Once you know if you have a 2D or 3D solution, you can skip ahead to the sections most relevant to you.

Look for the **2D**, **3D** or **2D/3D** indication next to each workflow to find out if it is relevant for your solution.

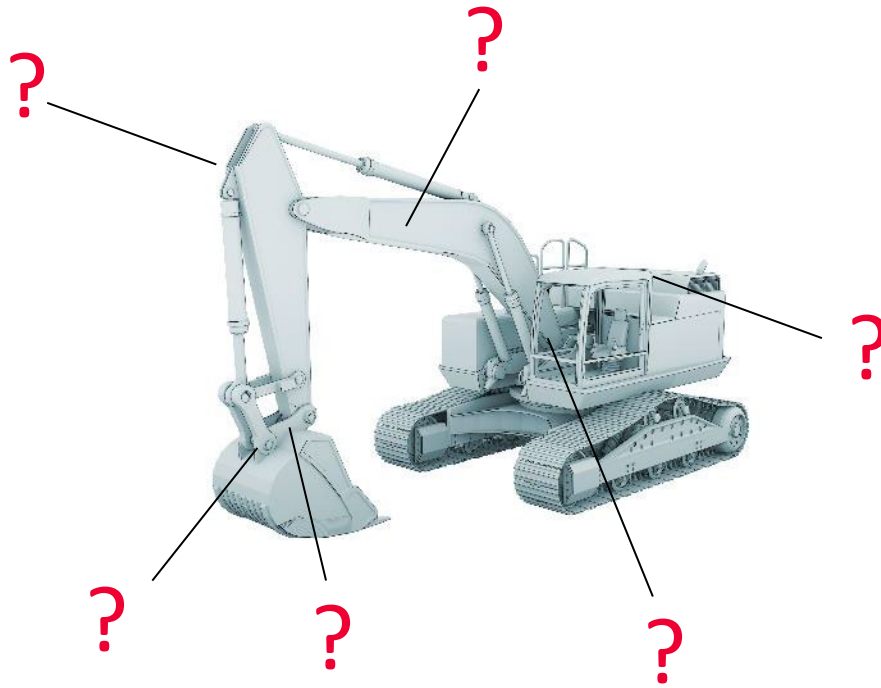

## Workflow 1.1. Find out what solution you have (2D or 3D?)

**Step 1:** Take a look at the machine control hardware components on your machine.

**Step 2:** Compare your set-up with the illustrations below. What solution do you have?

### 2D solution:

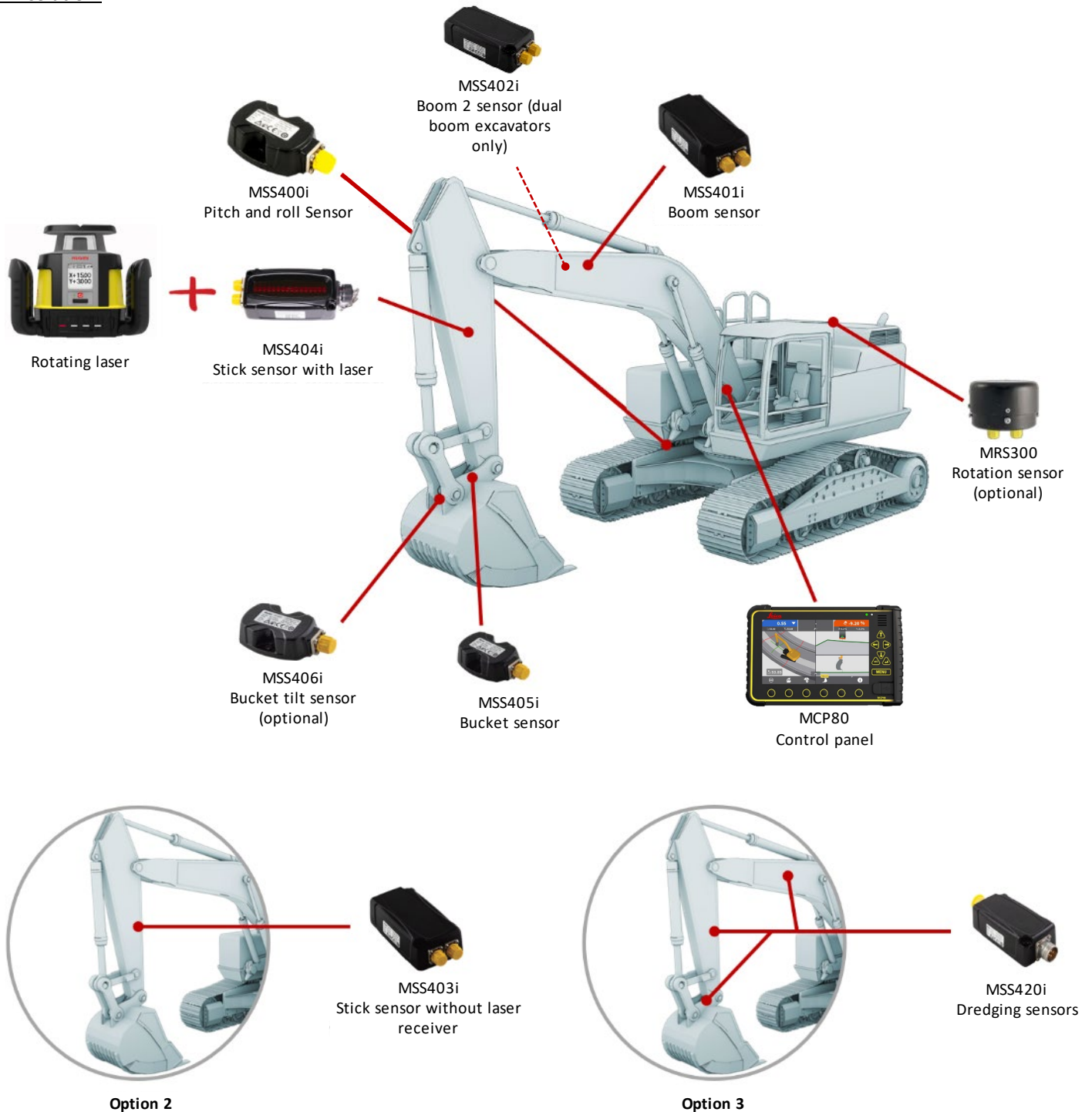

# Workflow 1.1. Find out what solution you have (2D or 3D?), (Continued)

## 3D solution:

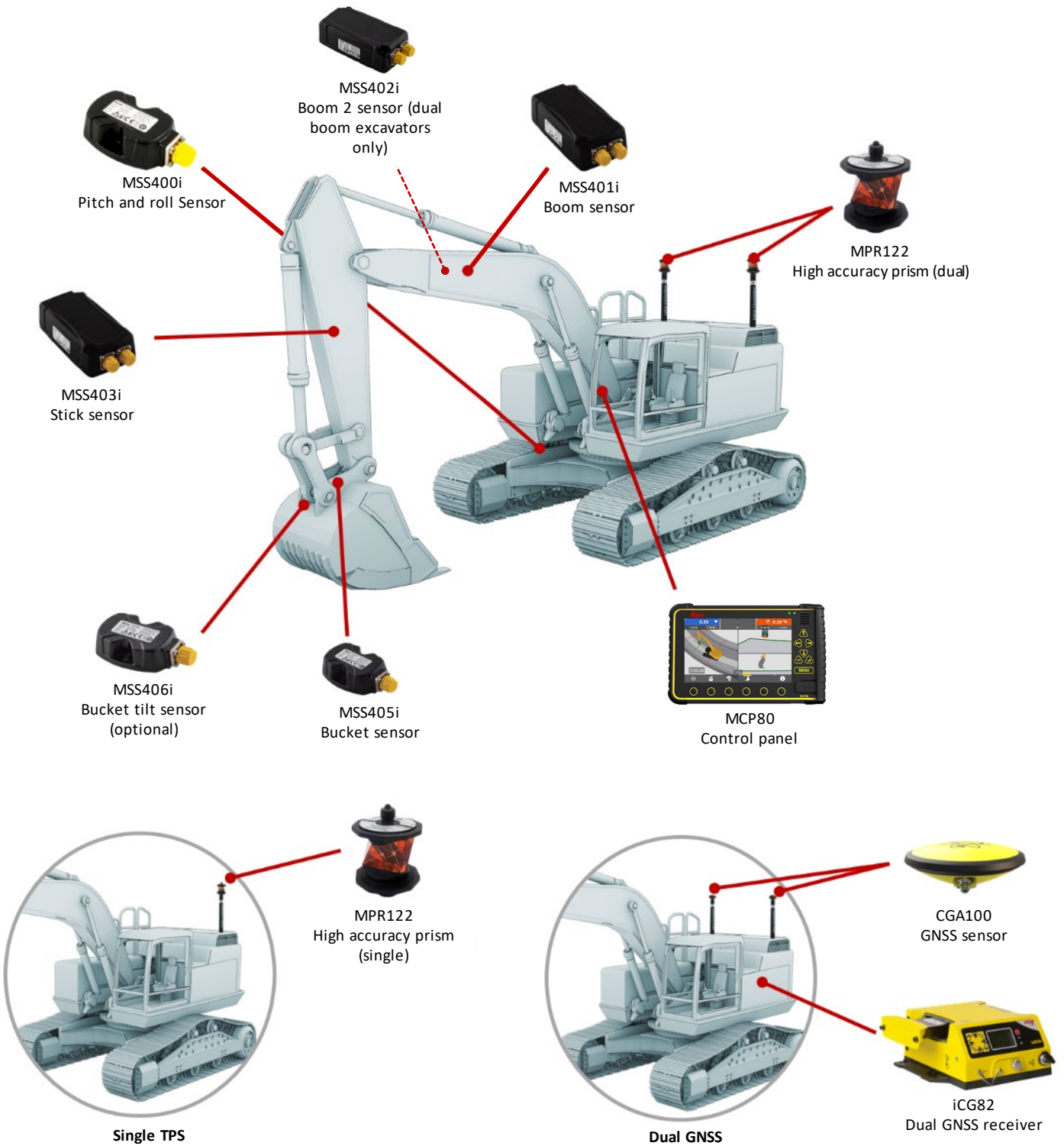

## 2. System

The following workflows focus on system related settings:

- **Workflow 2.1.** Change units (2D/3D).
- **Workflow 2.2.** Switch from 3D to 2D mode (2D/3D).
- **Workflow 2.3.** Use the MC1 on-screen help (2D/3D).

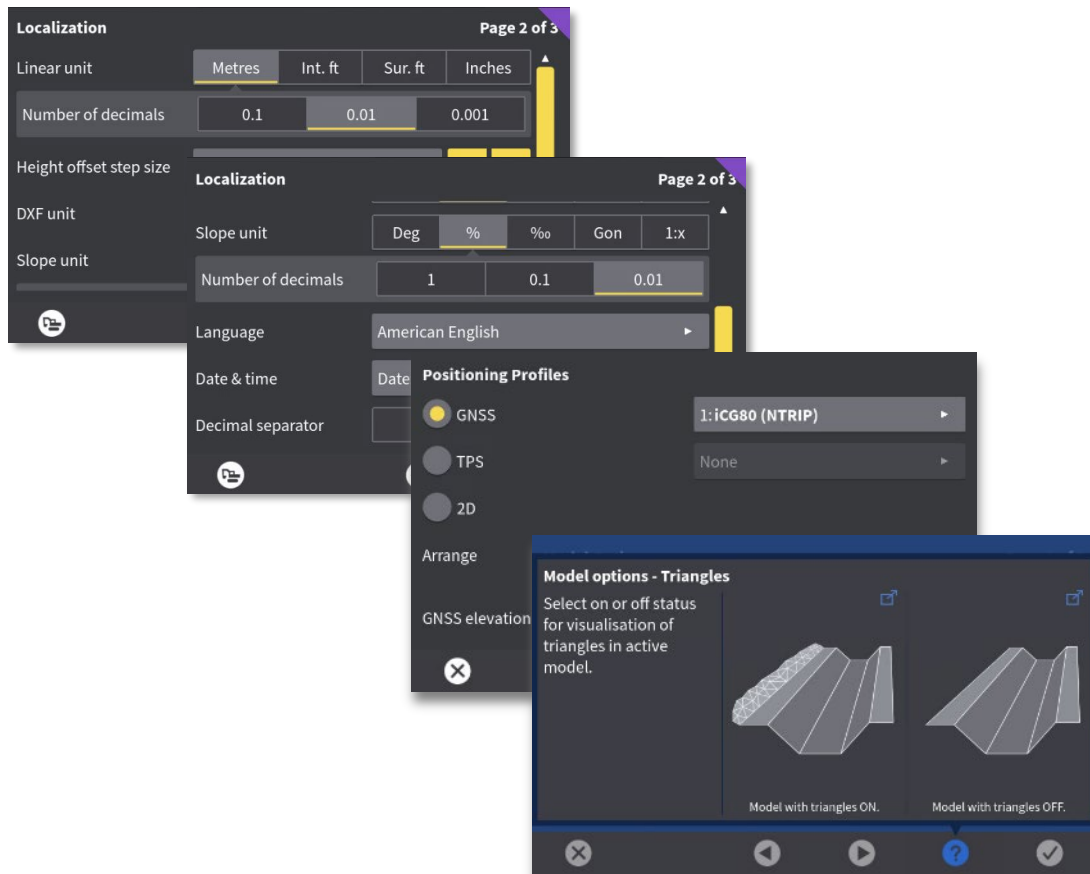

## Workflow 2.1. Change units (2D/3D)

You can change the unit in which distance and slope is measured (DXF/Slope units).

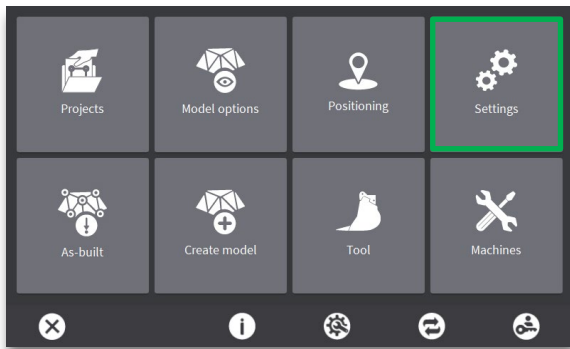

**Step 1:** Press the “Settings” menu.

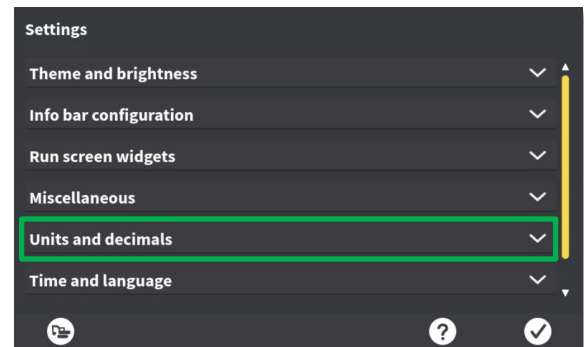

**Step 2:** Press right arrow (next).



**Step 3:** Tap the desired units to make changes to the current selection.

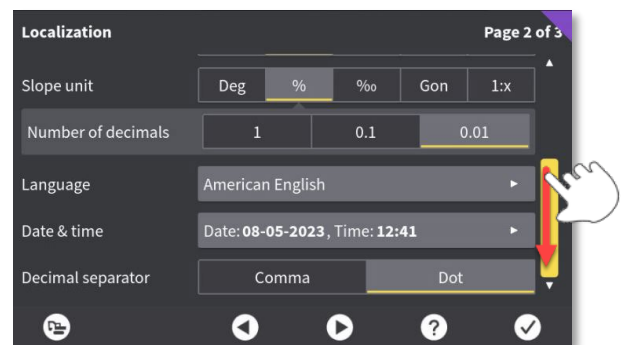

**Step 4:** Press and drag the vertical slider to view additional settings.

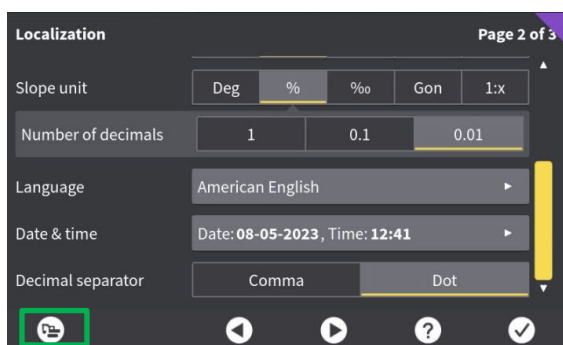

**Step 5:** Press machine icon to exit.

## Workflow 2.2. Switch from 3D to 2D mode (2D/3D)

You must access 2D mode from the "Positioning" menu.

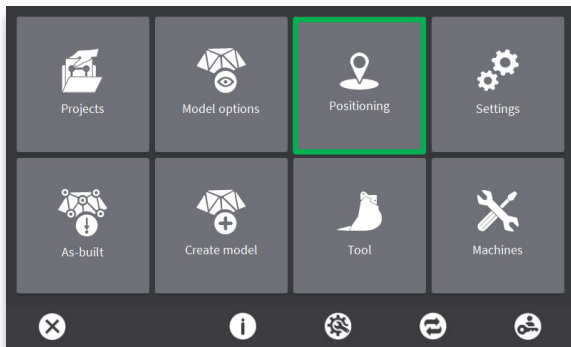

**Step 1:** Press the "Positioning" menu.

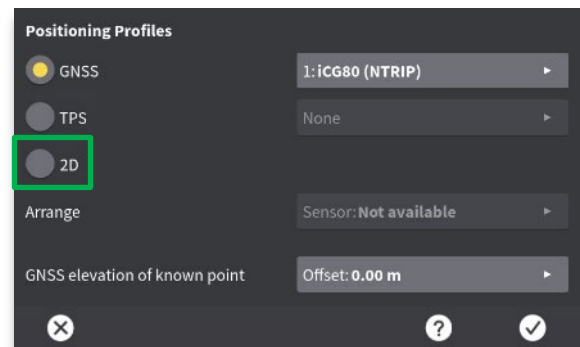

**Step 2:** Select "2D".

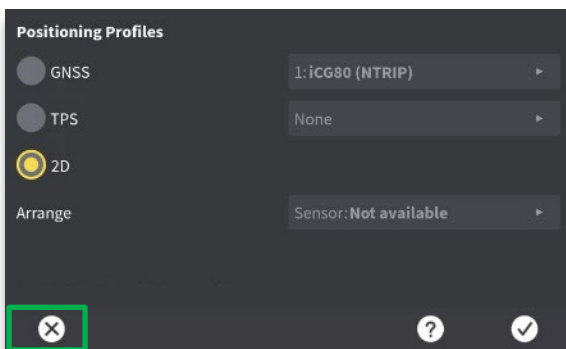

**Step 3:** Press X to return to run-screen.

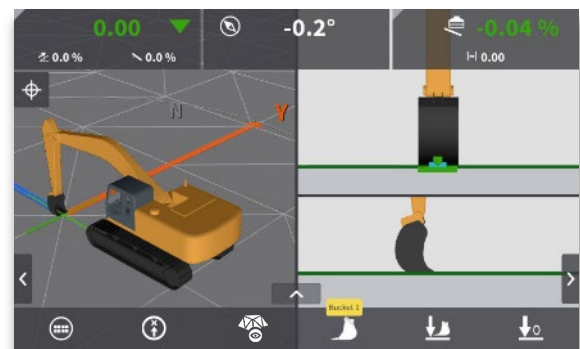

• 2D run screen is now shown.

## Workflow 2.3. Use the MC1 on-screen help (2D/3D)

Within the MC1 menus there is an additional feature to offer an explanation of the options on screen. Below is an example of only one MC1 help screen. Any menu screen that has a ? (question mark) at the bottom will have explanations available to the user.

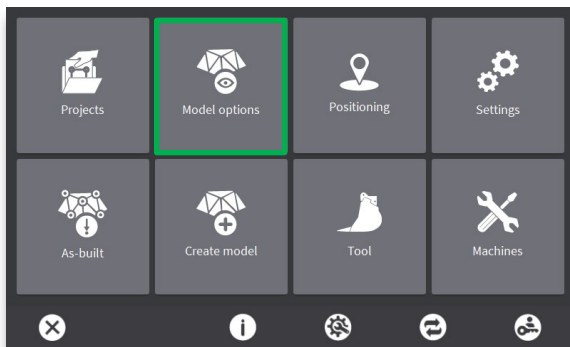

**Step 1:** Open any menu. "Model options" shown here.

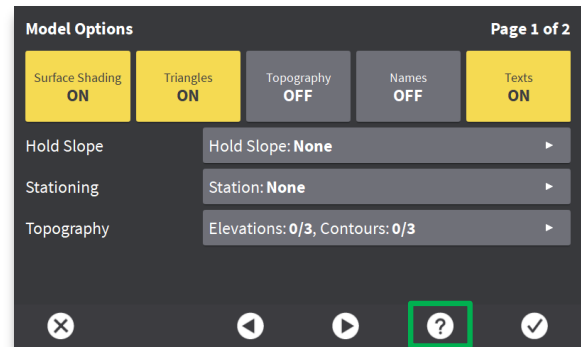

**Step 2:** Press ? (question mark).

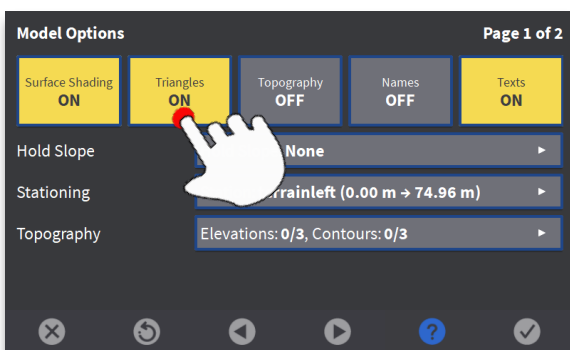

**Step 3:** Features with additional explanations offered are framed in blue. Press a blue framed feature to view its associated help screen. "Triangles" shown here.

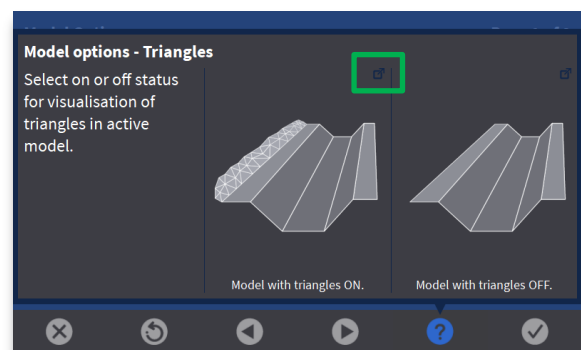

**Step 4:** Press the pop-out arrow to see a larger image of the illustration (if available).

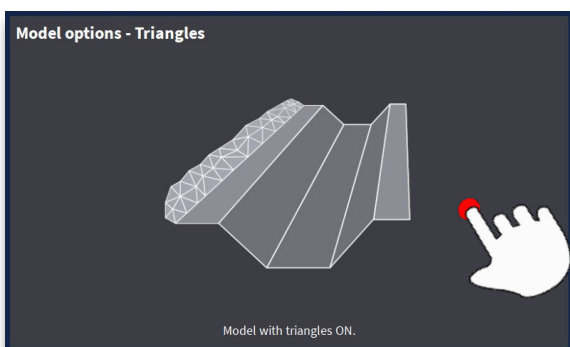

**Step 5:** Touch anywhere on this screen to close the pop-out illustration.

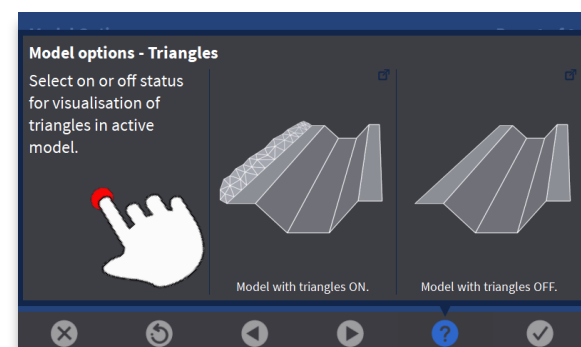

**Step 6:** Touch anywhere on this screen to close this specific help menu while remaining in the help selection mode.

## Workflow 2.3. Use the MC1 on-screen help (2D/3D), (Continued)

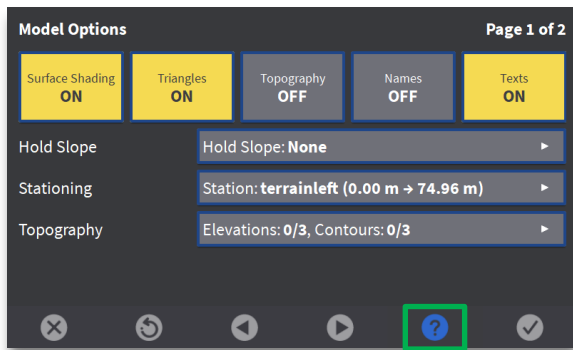

**Step 7:** Select another function to view or press ? to exit the help selection mode.

### 3. Run-screen indicators

The following workflows focus on the indicators available to you in the run-screen:

- **Workflow 3.1.** Activate tilt indicator (2D/3D).
- **Workflow 3.2.** Change indicators at top of run-screen (2D/3D).

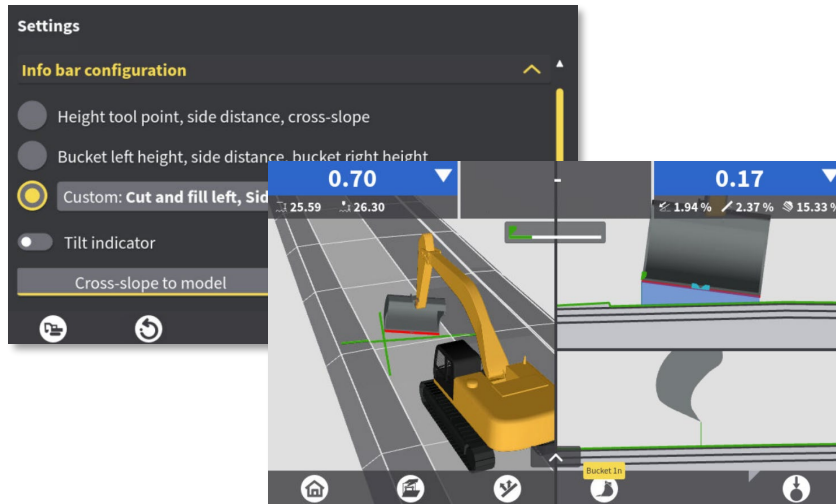

## Workflow 3.1. Activate tilt indicator (2D/3D)

The bucket tilt indicator is used to easily visualize the difference in your tool cross slope compared to the design cross slope. This workflow will show you how to toggle this feature on / off. Note the wedge of color will coordinate with the colors specified in tolerances. The run-screens shown are from a 3D solution, but the workflow also works for a 2D solution.



**Step 1:** Press the menu button.

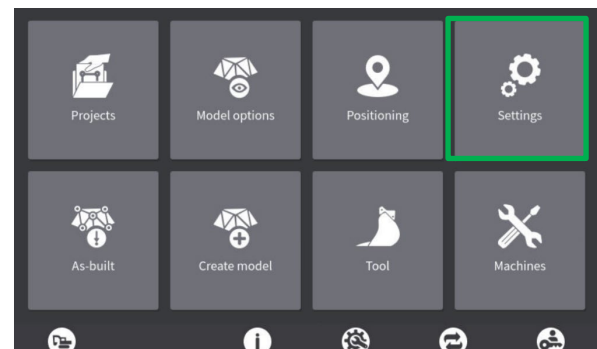

**Step 2:** Press the "Settings" menu.

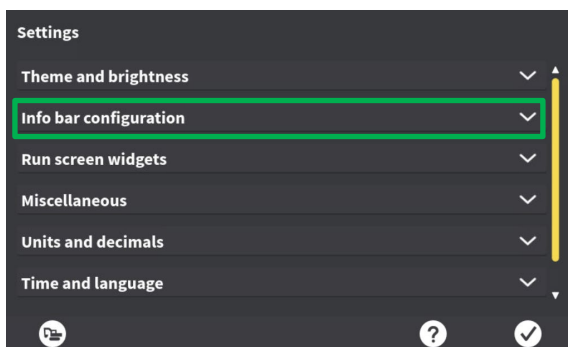

**Step 3:** Press "Info bar configuration".

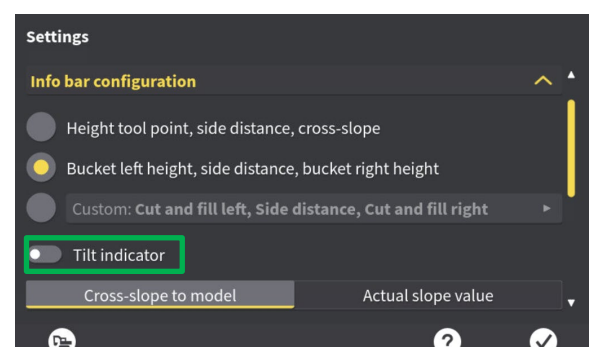

**Step 4:** Toggle on "Tilt indicator".

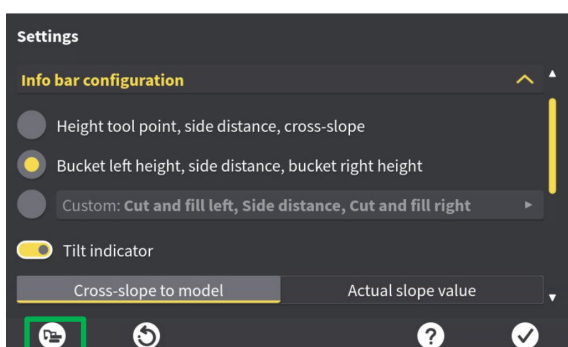

**Step 5:** Press excavator icon (exit).



- The cross-section screen will now show a wedge of colour indicating the gap between bucket cross-slope and design cross slope.

## Workflow 3.2. Change indicators at top of run-screen (2D/3D)

You can choose between two indicator options for 2D and three for 3D in the MC1 run-screen. The next pages provide a visual overview of the options for each solution, and tell you step by step how to select them. Settings for colors and tolerances are configured in "Main Menu > Tool > Tolerances.

### Indicator options for a 3D solution:

#### Height tool point – Side distance – Cross slope

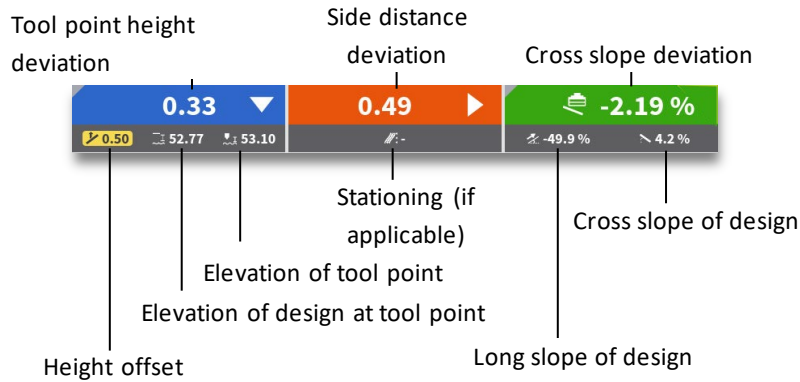

#### Bucket left height - Side distance - Bucket right height

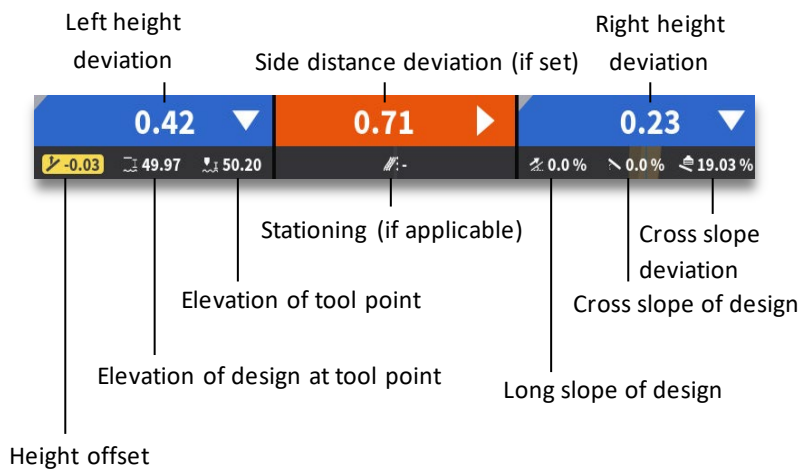

#### Custom

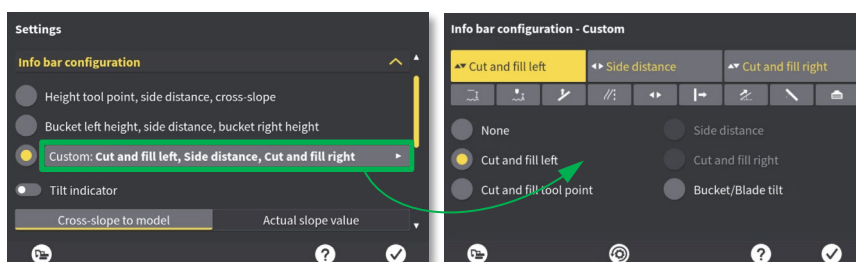

## Workflow 3.2. Change indicators at top of run-screen (2D/3D), (Continued)

### Indicator options for a 2D solution:

#### Height tool point – Direction – Cross slope

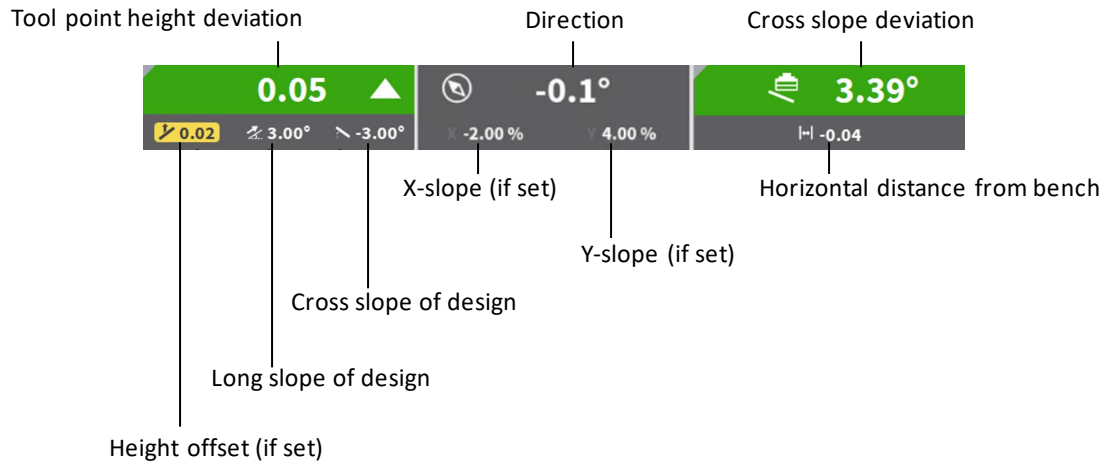

#### Bucket left height – Direction - Bucket right height

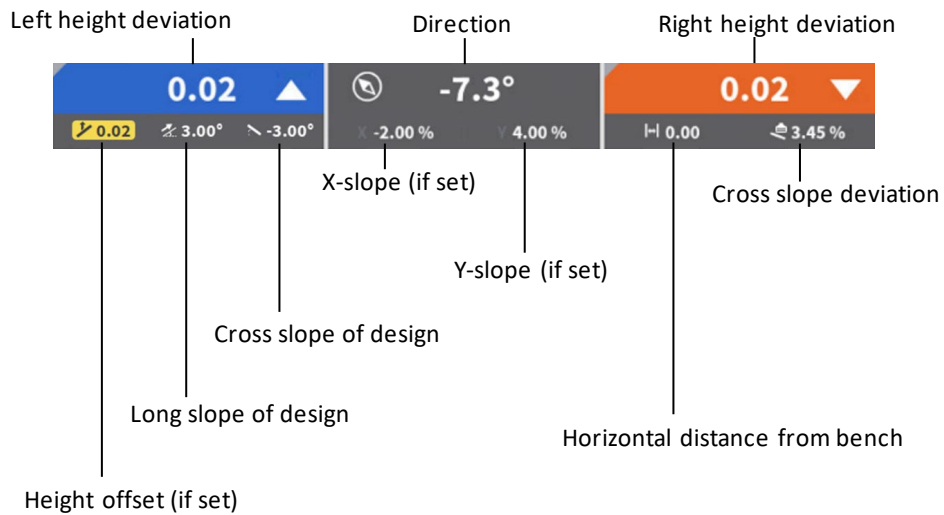

## Workflow 3.2. Change indicators at top of run-screen (2D/3D), (Continued)

The run-screens shown are from a 3D solution, but the workflow also works for a 2D solution.



**Step 1:** Press the menu button.

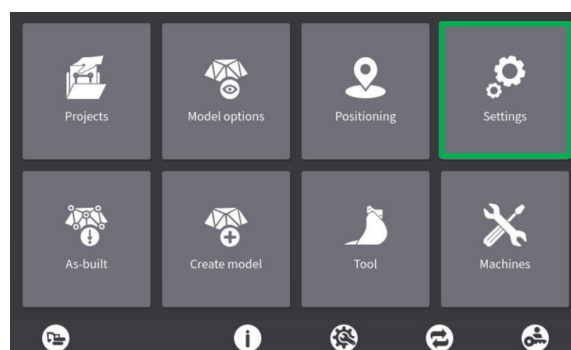

**Step 2:** Press the "Settings" menu.

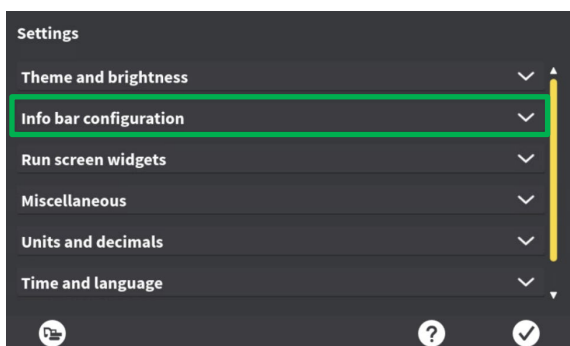

**Step 3:** Press the "Info bar configuration" menu.

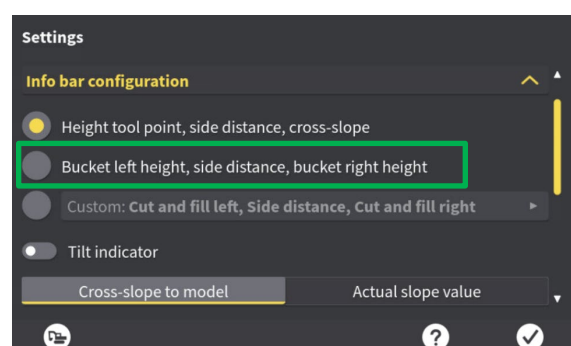

**Step 4:** Select desired indicator option. If you press the "Actual slope value" switch, the cross slope value changes from the deviation from target to actual cross slope value of cutting edge. This works for both 2D and 3D indicator options. Please note that custom configuration is only available for 3D.

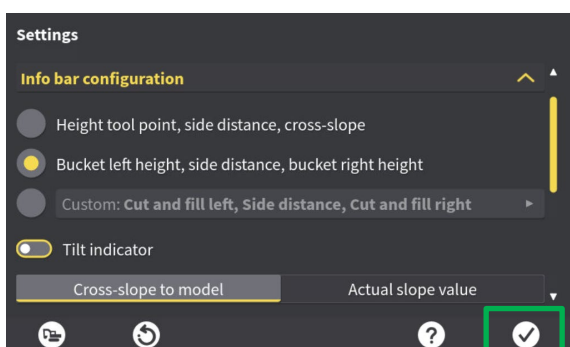

**Step 5:** Press tick mark to confirm and return to run screen.



- The run-screen indicators update to current selection (The 3D option "Bucket left height, direction, bucket right height" is shown here).

## 4. Bucket

The following workflows focus on the bucket:

- **Workflow 4.1.** Create a new bucket (2D/3D).
- **Workflow 4.2.** Re-calibrate a bucket (2D/3D).
- **Workflow 4.3.** Verify a bucket calibration (2D/3D).
- **Workflow 4.4.** Change bucket (2D/3D).
- **Workflow 4.5.** Change height tool point (2D/3D).
- **Workflow 4.6.** Select "closest to" height tool point (2D/3D).
- **Workflow 4.7.** Change side tool point (2D/3D).
- **Workflow 4.8.** Set direction of X (2D).
- **Workflow 4.9.** Bench bucket height (2D).
- **Workflow 4.10.** Offset benched bucket height (2D).
- **Workflow 4.11.** Set bucket slope values (2D).
- **Workflow 4.12.** Use moving point (load/store), (2D).

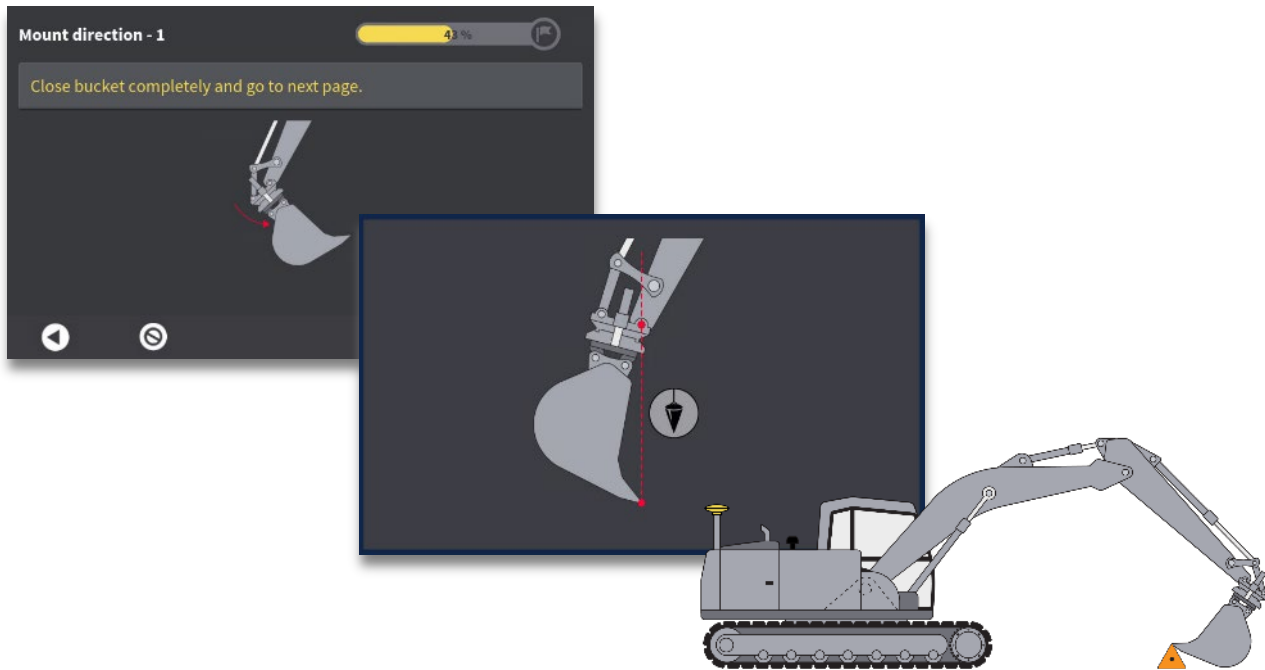

## Workflow 4.1. Create a new bucket (2D/3D)

Create a bucket profile for each tool you will be using to easily change between them while working with MC1.

You may create up to 100 buckets to be saved in the system.

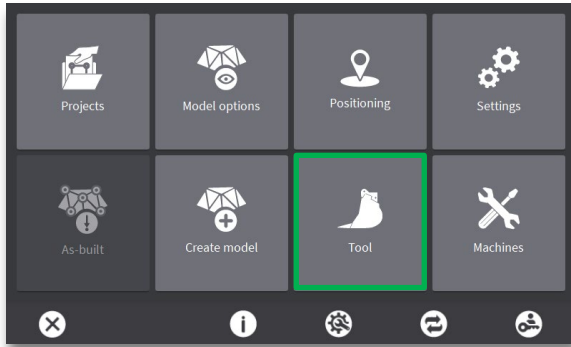

**Step 1:** Press the "Tool" menu.

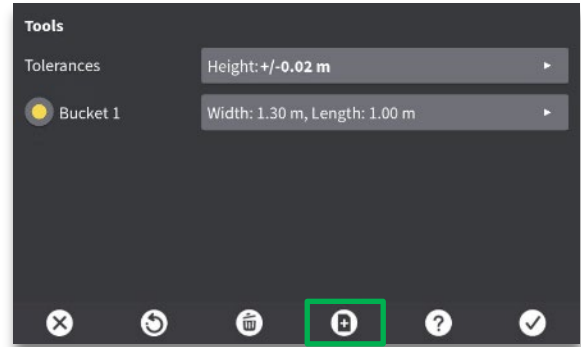

**Step 2:** Press the "new bucket" icon.

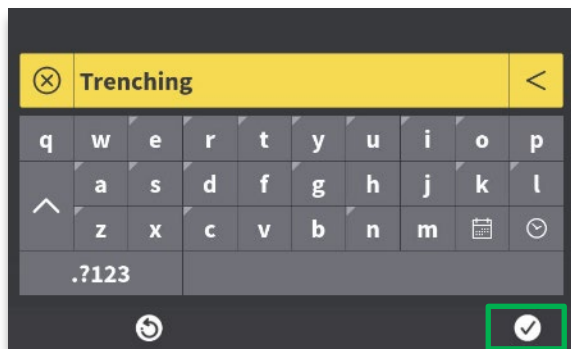

**Step 3:** Enter a name for the new bucket and press tick mark icon (OK).

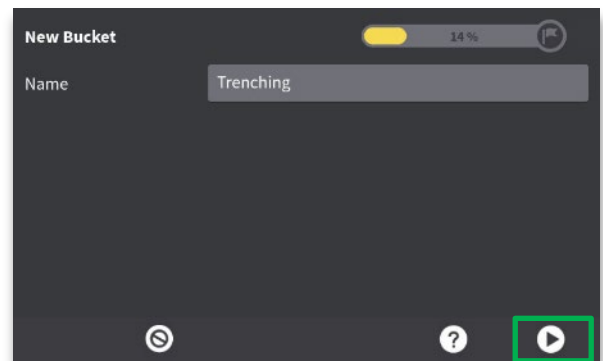

**Step 4:** Press right arrow (next).

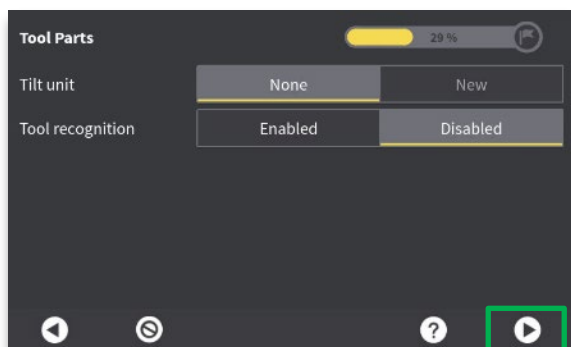

**Step 5:** Select "tilt unit" and "tool recognition" (if applicable). Press right arrow (next).

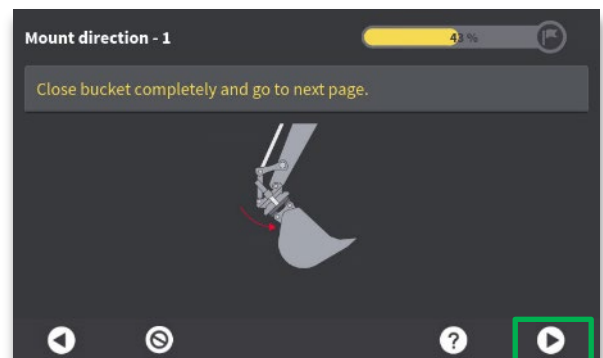

**Step 6:** Close the bucket completely and press right arrow (next).

## Workflow 4.1. Create a new bucket (2D/3D), (Continued)

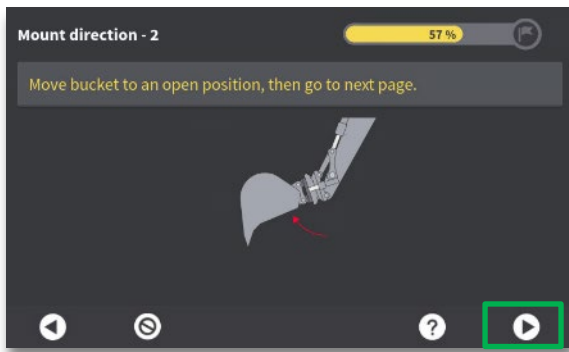

**Step 7:** Open the bucket, then press right arrow (next).

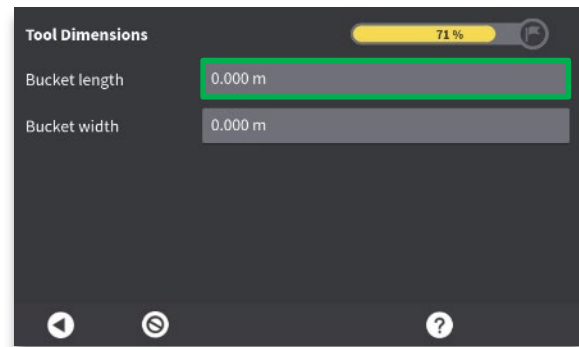

**Step 8:** Press the "Bucket length" value field.

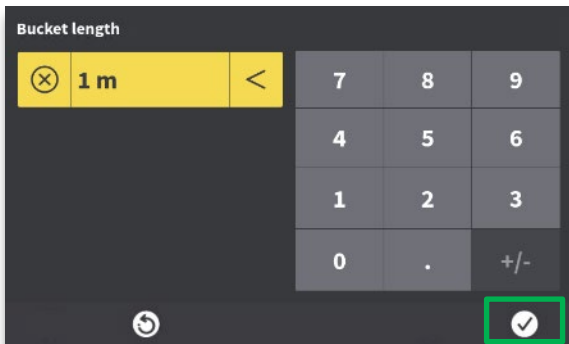

**Step 9:** Measure your current "bucket length" and enter the value. Press tick mark icon (OK).

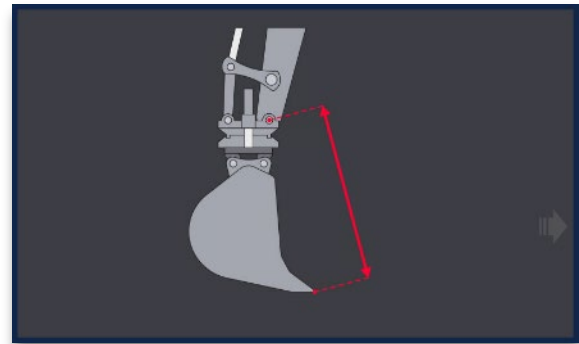

- Bucket Length.

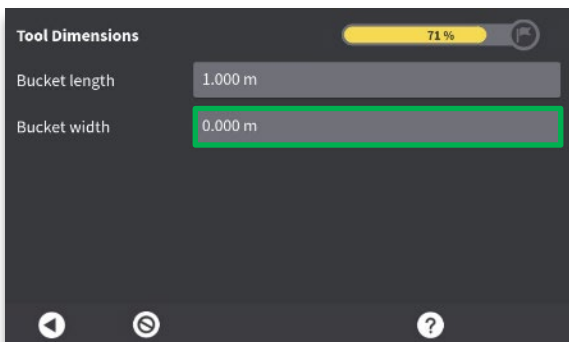

**Step 10:** Press the "Bucket width" value field.

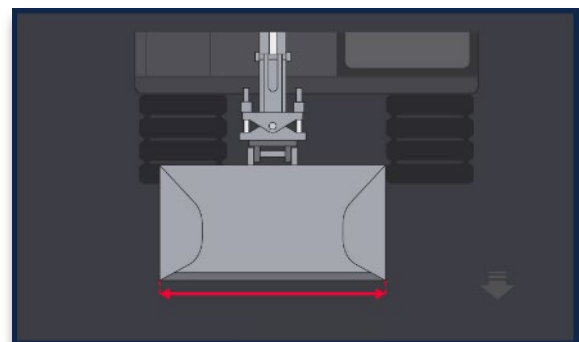

- Bucket Width.

## Workflow 4.1. Create a new bucket (2D/3D), (Continued)

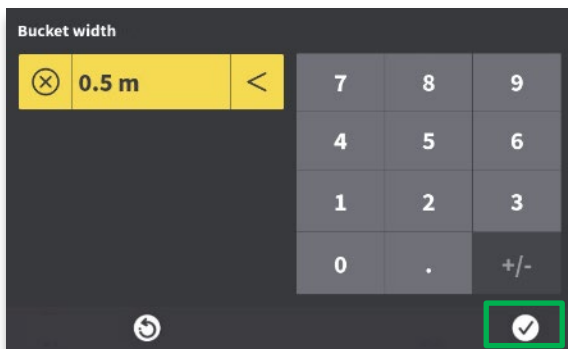

**Step 11:** Enter current bucket width. Press tick mark icon (OK).

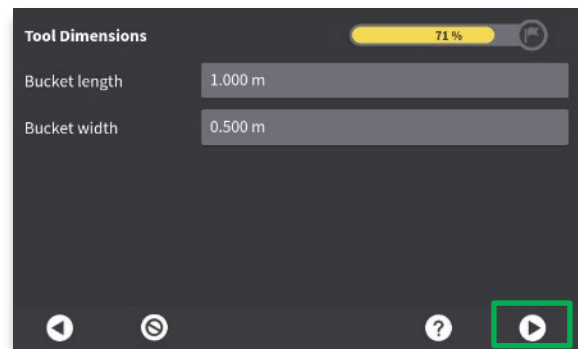

**Step 12:** Ensure entered values are correct, then press right arrow (next).

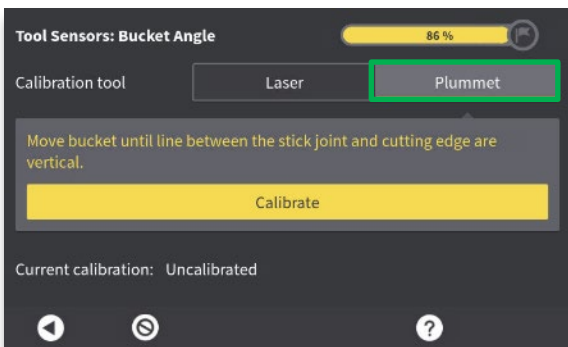

**Step 13:** Select a tool to be used for bucket calibration (plummet shown here).

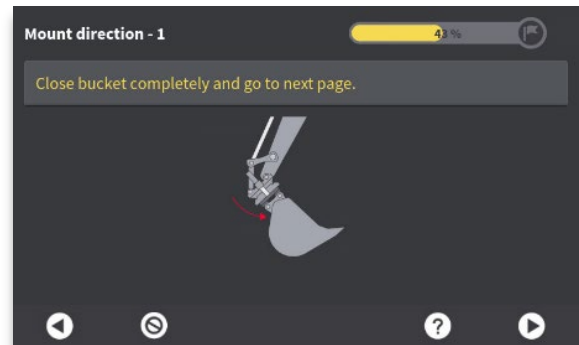

**Step 14:** Open or close the bucket so tip of bucket is vertically aligned with bucket pivot point. Use a plummet, or carpenter's level, to verify angle.

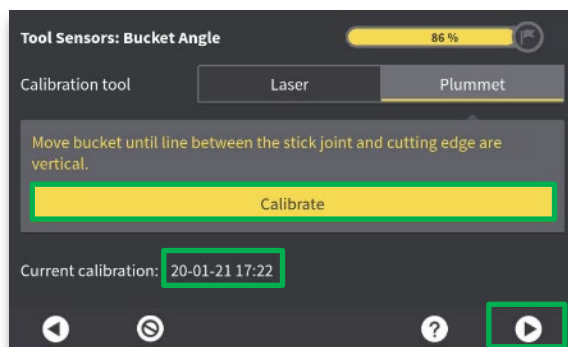

**Step 15:** Press "Calibrate". Calibration date/time is recorded for future reference. Press right arrow (next).

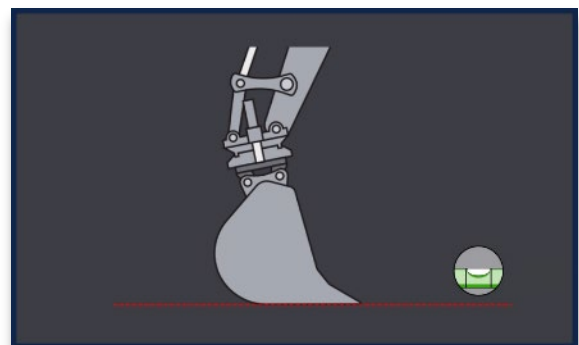

**Step 16:** Close the bucket until bottom edge is horizontal. Use a carpenter's level to verify flat angle.

## Workflow 4.1. Create a new bucket (2D/3D), (Continued)

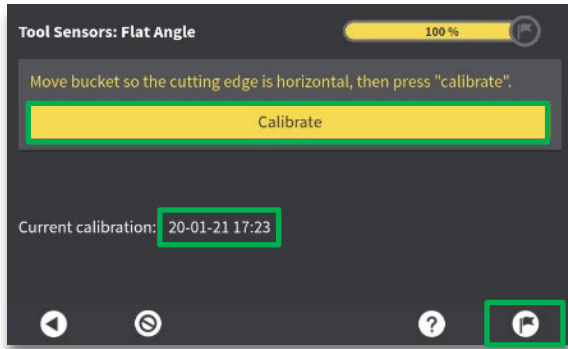

**Step 17:** Press "Calibrate". Calibration date/time is recorded for future reference. Press flag icon.



**Step 18:** Press tick mark icon (OK).

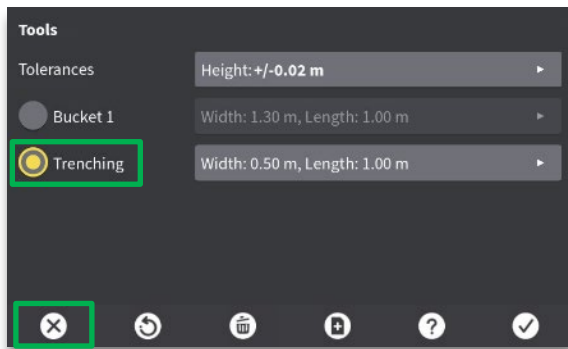

**Step 19:** The newly created bucket will be selected. Press X (exit).



- Current bucket is shown in run-screen. Bucket name is displayed above the bucket icon in the quick access bar.

## Workflow 4.2. Re-calibrate a bucket (2D/3D)

Re-calibrate when the cutting edge has been changed or has been worn down significantly.

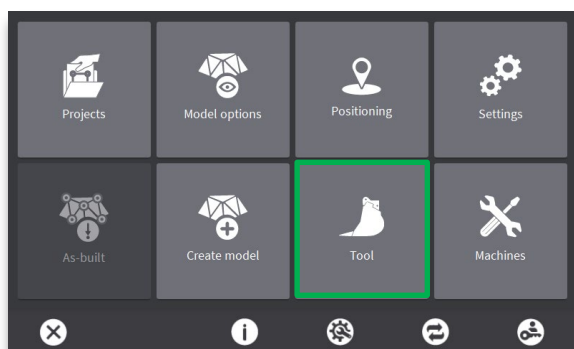

**Step 1:** Press the “Tool” menu.

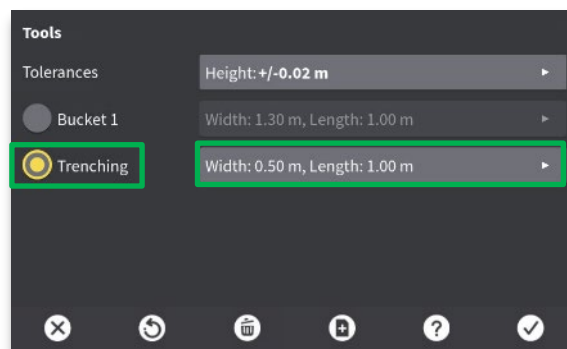

**Step 2:** Select the bucket you want to re-calibrate. Press menu next to selected bucket.

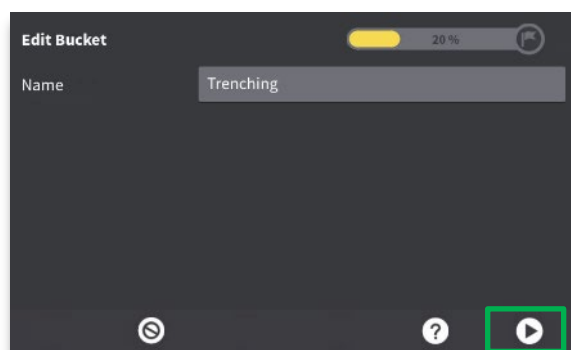

**Step 3:** Proceed with the same steps as when creating a new bucket ([Workflow 4.1](#), Step 4 and onward).

## Workflow 4.3. Verify a bucket calibration (2D/3D)

Bucket verification is a critical step. When verifying your bucket calibration, you bench the machine on a point, change geometry of bucket/stick angle, and then re-check the point (Open/closed bucket).

This verification is done in the 2D run-screen.

It is recommended to verify your bucket on a regular basis, not only when creating/re-calibrating a bucket.

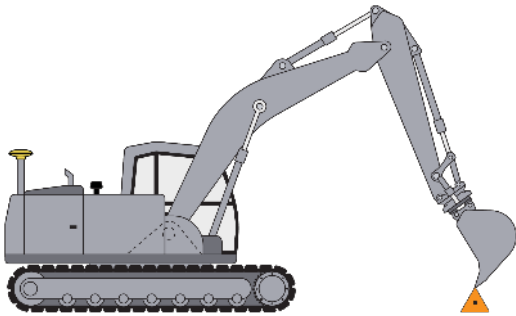

**Step 1:** Position your machine so that you can place the open bucket on a reference point.

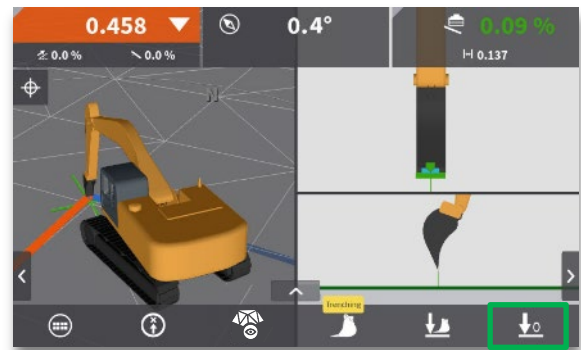

**Step 2:** Ensure tool point matches bucket position on the reference. Press the "bench 0" icon.



- Confirmation of bench appears briefly.

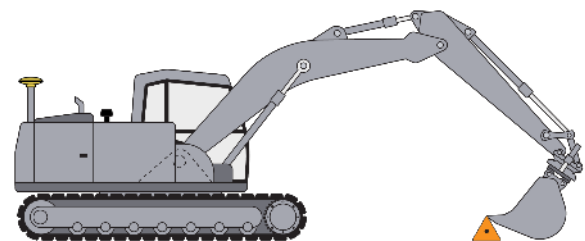

**Step 3:** Change the bucket/stick angle and place the same tooth back on the reference point.

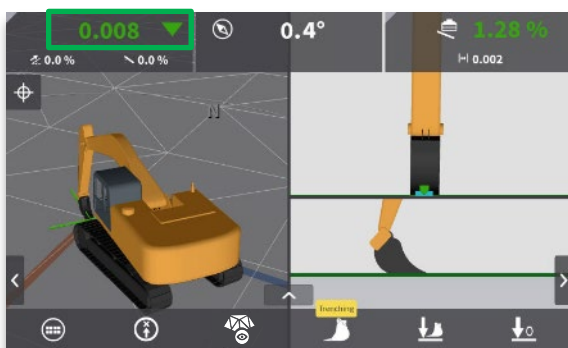

**Step 4:** Confirm that height difference is less than +/-10mm.

### NOTE:

- If height difference is greater than +/-10mm, check that you have selected the right bucket, or re-calibrate your bucket.

## Workflow 4.4. Change bucket (2D/3D)

When changing the bucket, you can easily select from a list of pre-configured buckets.

If the desired bucket is not listed, you will need to create the bucket first ([Workflow 4.1.](#)).

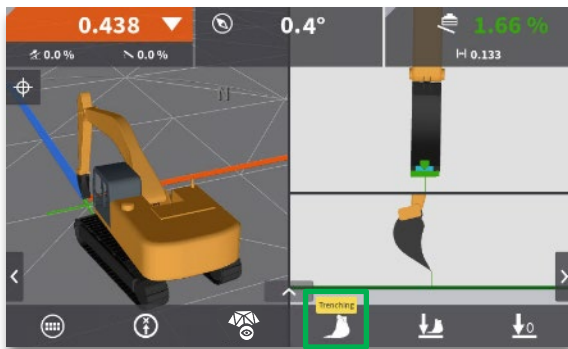

**Step 1:** Press the bucket icon.

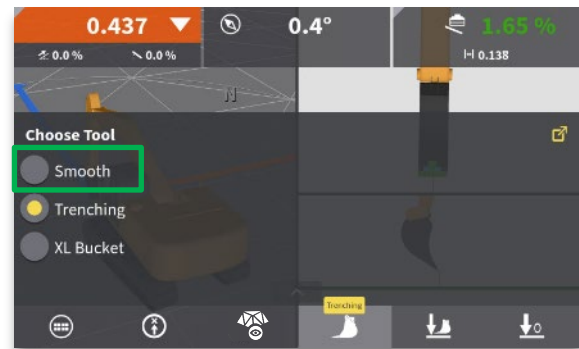

**Step 2:** Press the desired bucket to select it.

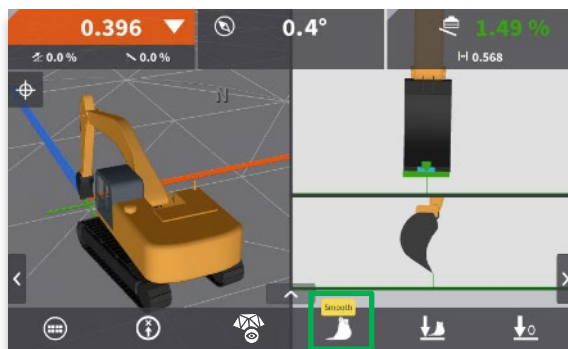

- The new bucket will be automatically applied, and its name will be visible above the bucket icon in the quick access bar.

## Workflow 4.5. Change height tool point (2D/3D)

The height tool point defines where MC1 looks for elevation guidance, when a height reference is selected.

See also [Workflow 9.1](#). Select and use a height reference (3D).

The **up** and **down** hard keys on the MCP80 panel toggle selected height tool point.



**Step 1:** Verify height tool point position. Height tool points are represented by a green icon on the blade (Left height tool point is shown).



**Step 2:** Press **up** hard key to toggle height tool point to middle position.



**Step 3:** Press **up** hard key to toggle height tool point to right tip position.



**Step 4:** Press **down** hard key to toggle height tool point in opposite direction.

### NOTE:

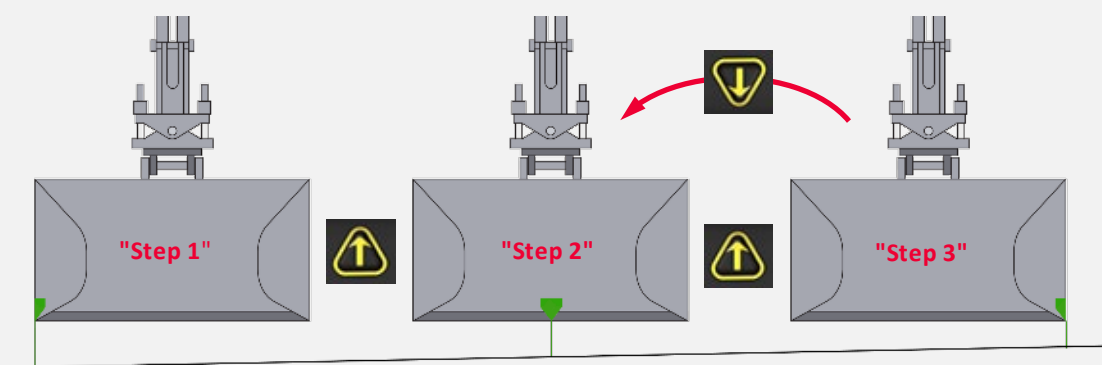

## Workflow 4.6. Select "closest to" tool point (2D/3D)

When working in auto mode, it is recommended to use the height tool point that is closest to your design. You can select the "closest to" height tool point in the "Model options" menu. This allows the system to dynamically select the height tool point that is closest to the design.

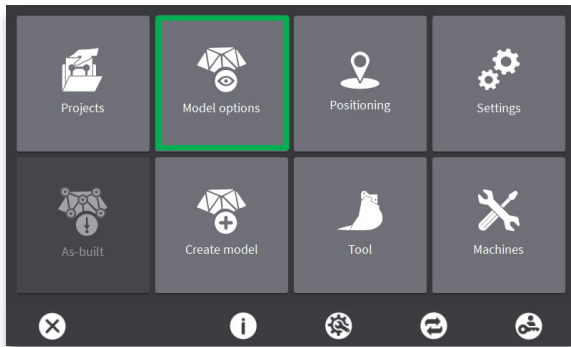

**Step 1:** Press the "Model options" menu.

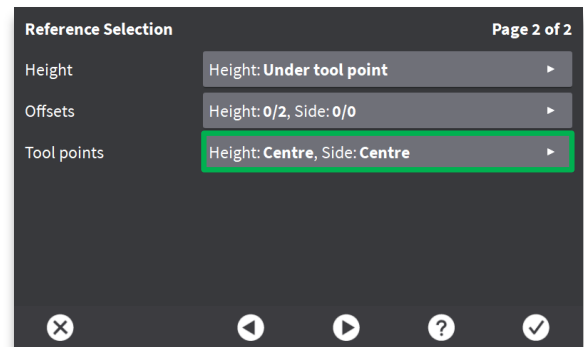

**Step 2:** Press the "Tool points" menu (page 2).

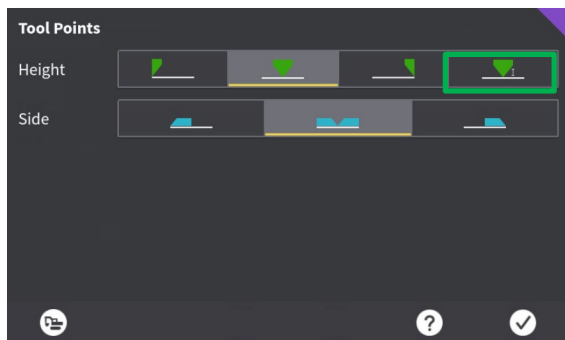

**Step 3:** Select the height tool point indicator representing "closest to".

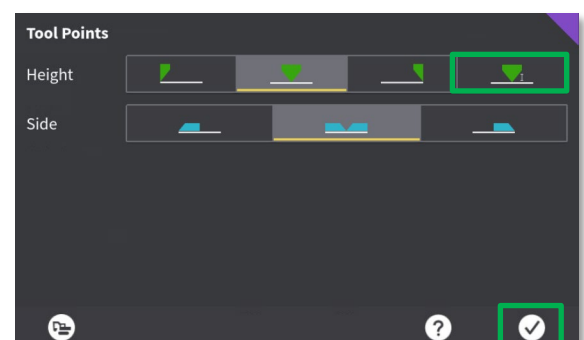

**Step 4:** Press tick mark icon (exit).

### NOTE:

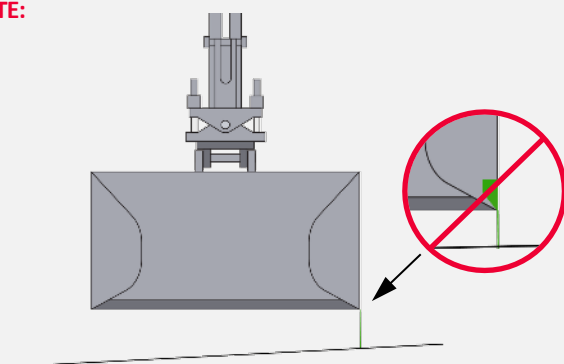

The typical green arrow indicating the height tool point will not be shown when "closest to" height tool point has been selected. The green line will still appear, and change position depending on what tool point is closest to the design.

## Workflow 4.7. Change side tool point (2D/3D)

The side tool point defines where MC1 looks for horizontal guidance, when a side reference is selected.

See also [Workflow 9.2](#). Select and use a side reference (3D).

The **left** and **right** hard keys on the MCP80 panel toggle selected **side tool point**.



**Step 1:** Verify side tool point position. Side tool points are represented by a "teal" icon on the blade (Left side tool point is shown).



**Step 2:** Press **right** hard key to toggle side tool point to middle position.



**Step 3:** Press **right** hard key to toggle side tool point to right tip position.



**Step 4:** Press **left** hard key to toggle side tool point in opposite direction.

## Workflow 4.8. Set direction of X (2D)

When working in dual slope mode (bucket or laser for reference) you can dial in a grade for both slope directions Y and X. Before digging with an added slope value, you must first set direction of X.

This workflow illustrates the traditional way of using one point, with a known direction of X.

A more advanced method is to use two points, which is useful when working with a stringline for example.

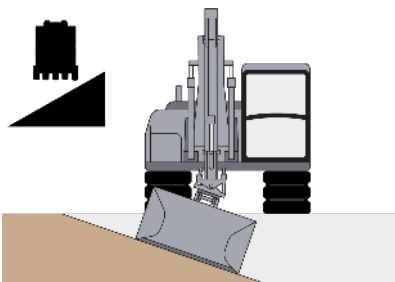
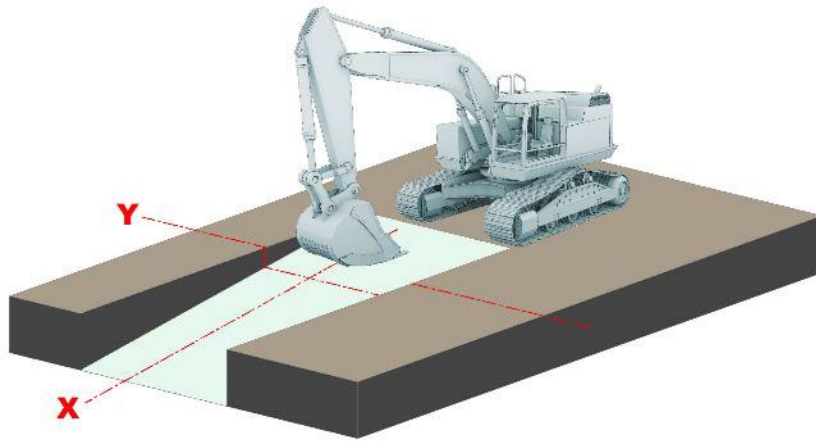

**Y slope:** Allows you to dial in a grade that slopes perpendicular to the boom.

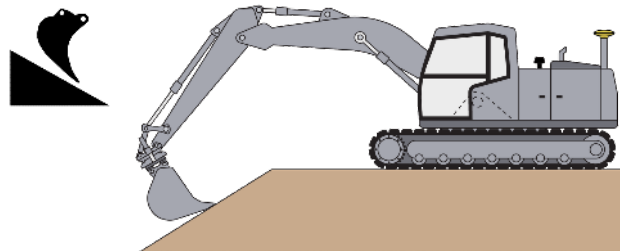

**X slope:** Allows you to dial in a grade that slopes parallel with the boom.

Why setting the direction of X is important:

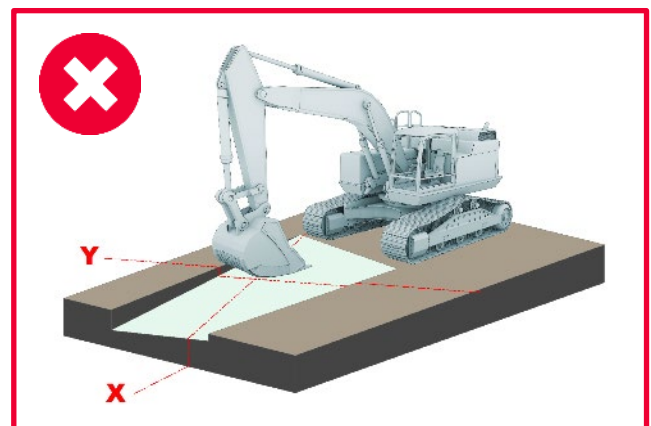
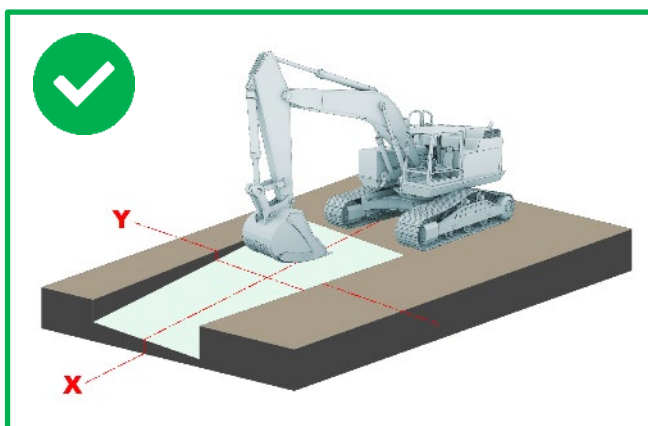

## Workflow 4. 8. Set direction of X (2D), (Continued)

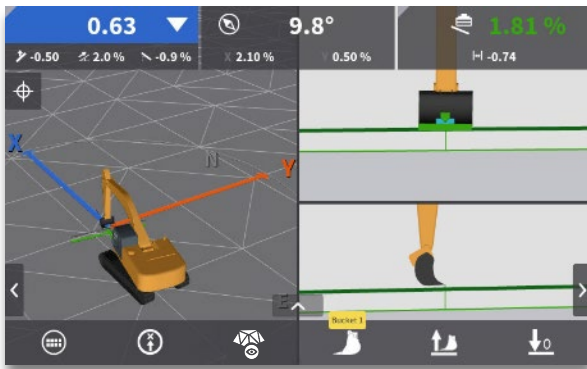

- When working in 2D the direction of X is indicated by a blue arrow on the ground in the plan view.

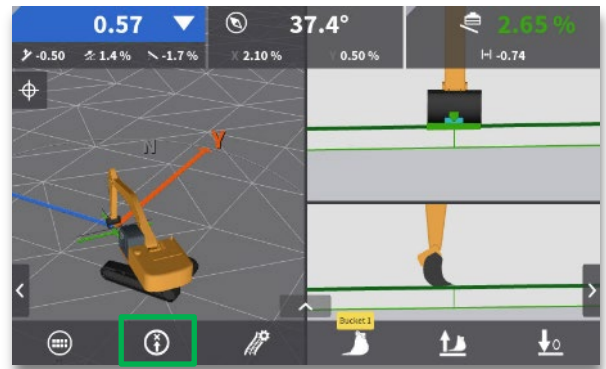

- Step 1:** Turn your machine so the boom points toward the desired direction of X, then press the "set X-direction" button.

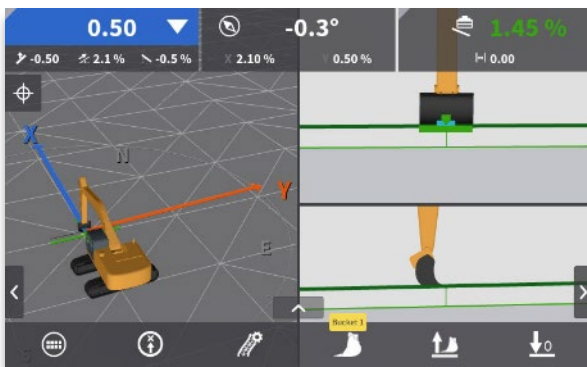

- The blue arrow on the ground, in the plan view, now reflects the new direction of X.

## Workflow 4.9. Bench bucket height (2D)

The benchmark is a point of reference from which measurements can be made.

When using the bucket for reference, before you begin digging, or whenever you move to a new working position, you must bench your machine. Alternatively, you can carry your previous bench with "moving point" ([Workflow 4.12](#)).

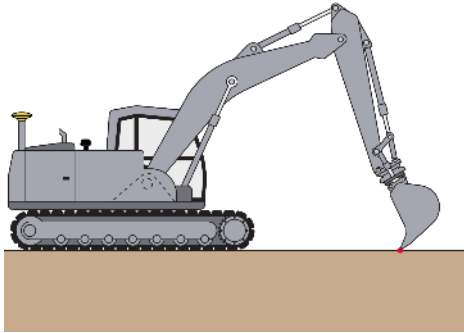

**Step 1:** Place bucket tip on desired reference point, without disturbing its position.

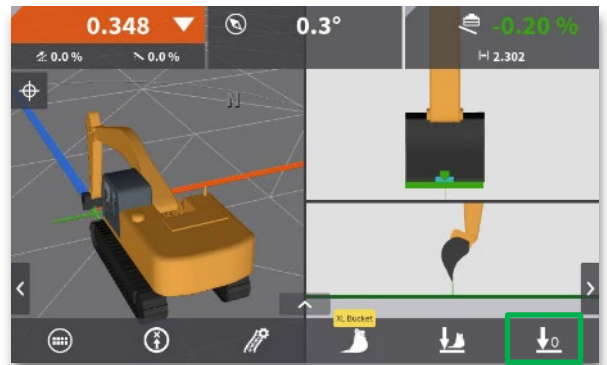

**Step 2:** Press the "bench 0" button.

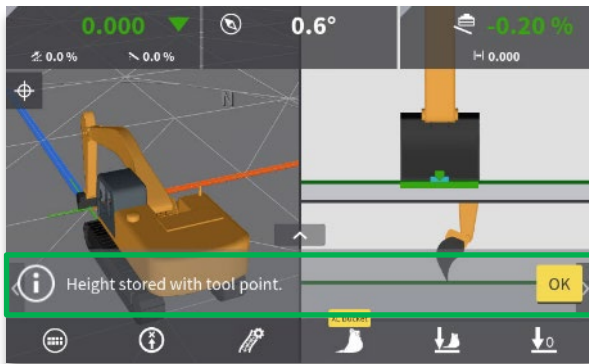

- Confirmation appears briefly. The 2D system is now benched on current reference point.

### NOTE:

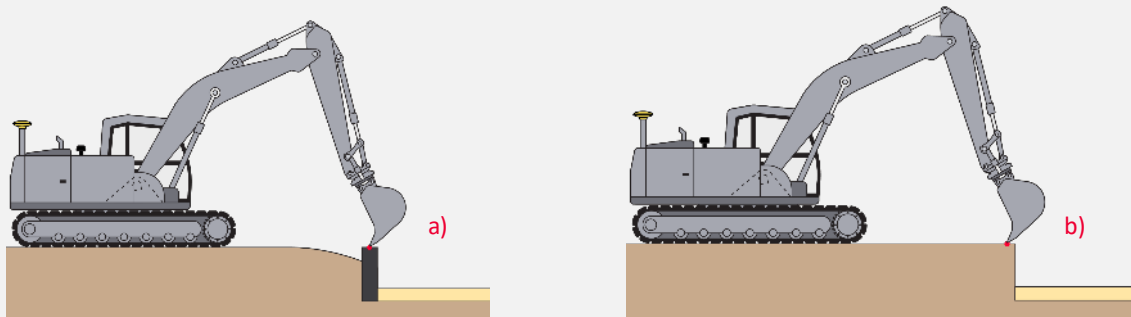

Benchmark examples:

- A mark on a permanent object indicating elevation, such as a concrete post set into the ground.  
**Useful when digging to a specific elevation.**
- A generic reference point on the ground, used as a starting point.  
**Useful when digging a specific depth.**

## Workflow 4.10. Offset benched bucket height (2D)

It is often desirable to enter a height offset after benching. This is used to establish dig depth so the MC1 system can provide guidance to the desired elevation.

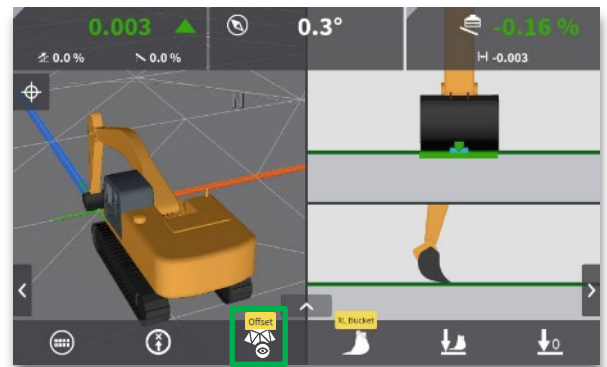
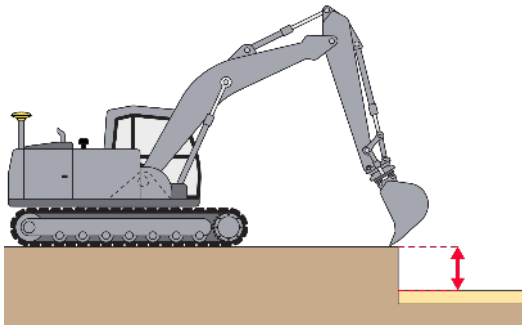

**Step 1:** Press the model options menu.

- Height offset = distance between benched reference height and desired dig level.

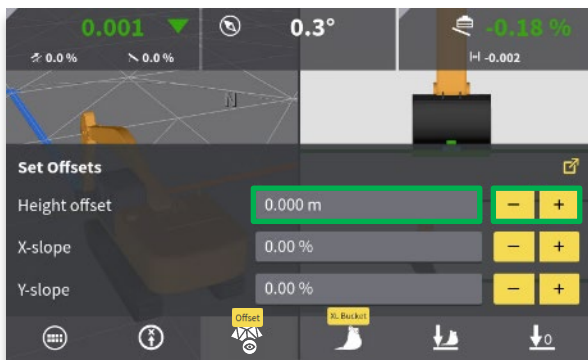

**Step 2:** Use +/- to toggle height offset, or press the value field to enter a value.

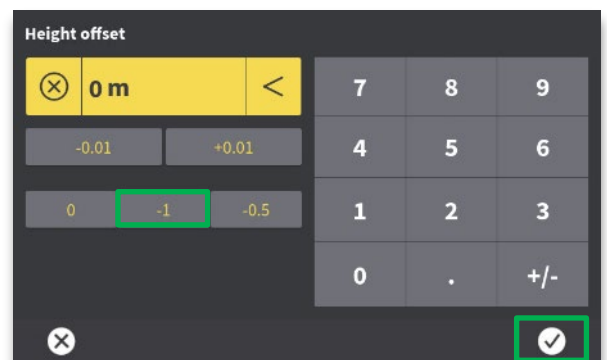

**Step 3:** Enter a specific value on the keypad. Alternatively, select -0,01m/+0,01m or one of the past three offsets. Press tick mark icon (OK).

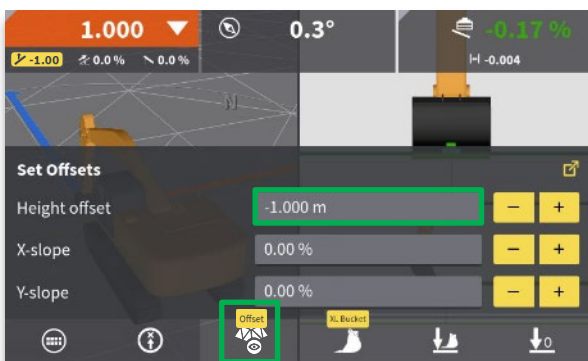

**Step 4:** Verify applied offset. Press the model options menu to return to run-screen.

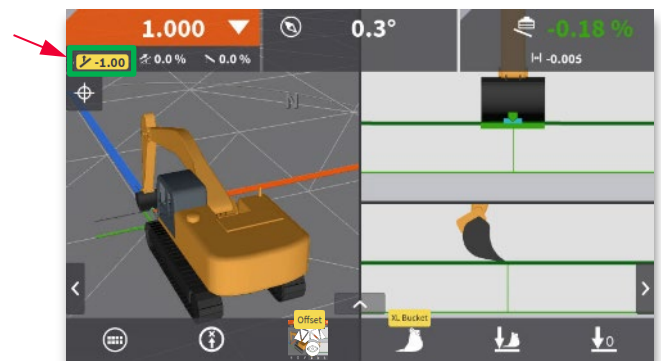

- Cut/fill values are provided to the offset, and applied height offset is displayed in the secondary value bar. The offset surface is also illustrated in the cross/long section views.

## Workflow 4.11. Set bucket slope values (2D)

You can enter a slope value for X-slope, and if dual slope is desired, then Y-slope can also be dialed in.

X direction must be set before using dual slope ([Workflow 4.8](#)).

### NOTE:

Examples of negative/positive X and Y-slope values:

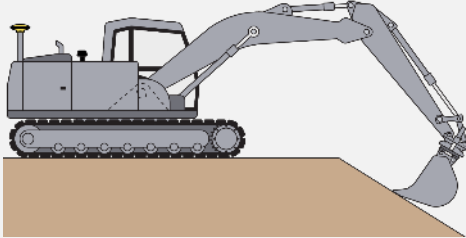

Positive X-slope value

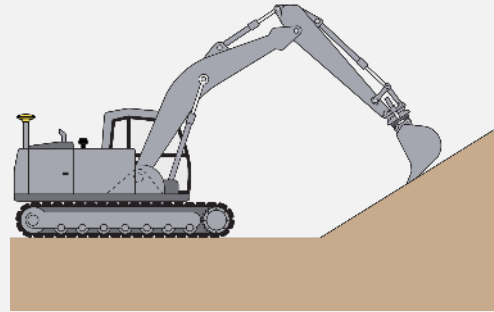

Negative X-slope value

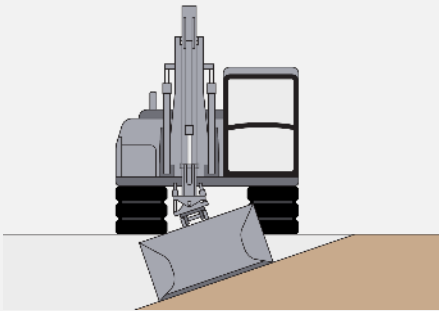

Positive Y-slope value

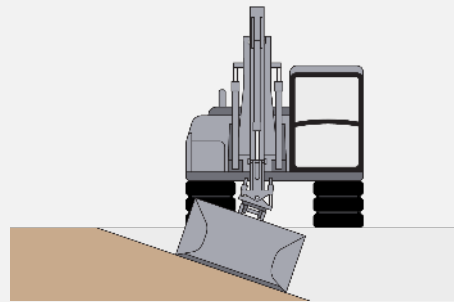

Negative Y-slope value

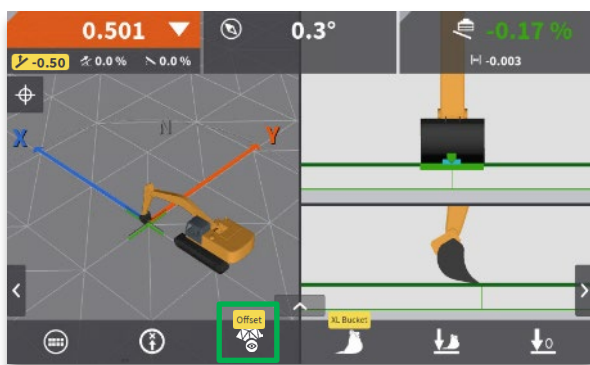

**Step 1:** Press the model options menu to change the X- or Y-slope value.

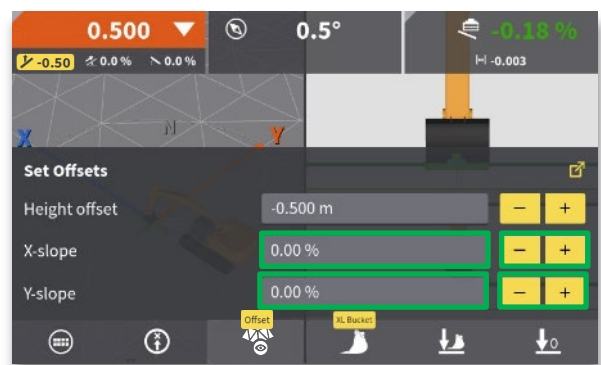

**Step 2:** Use +/- to toggle X- or Y-slope, or press the value field to enter a value.

Continued on next page.

## Workflow 4.11. Set bucket slope values (2D), (Continued)

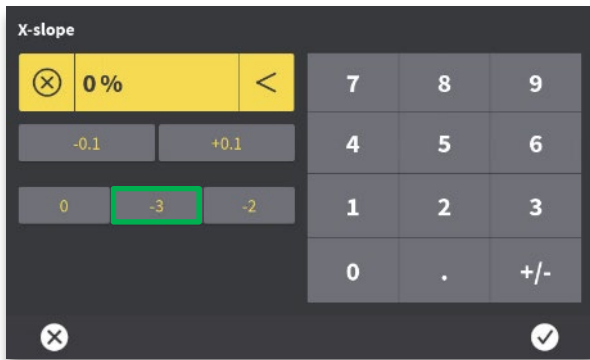

**Step 3:** Enter a specific value on the keypad. Alternatively, select -0,01m/+0.01m or one of the past three offsets. Press the tick mark icon (OK).

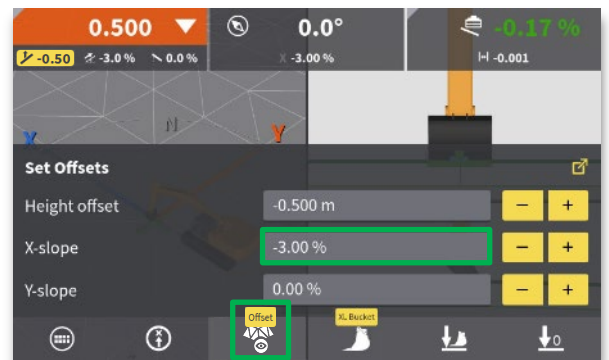

**Step 4:** Verify applied slope values. Press the model options menu to return to run-screen.

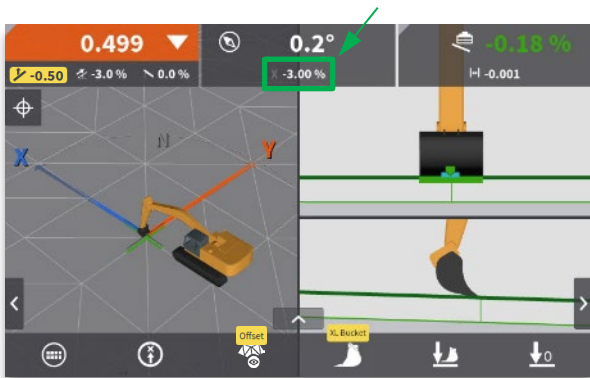

- Applied slope value is displayed in the secondary value bar. The offset and sloped surface is also illustrated in the cross/long section views.

## Workflow 4.12. Use moving point (load/store), (2D)

When using a bucket for reference, you can use moving point (load/store) to transfer a benched elevation by a common reference point. Moving point (load/store) is only applicable after the system has been benched. It requires a sturdy reference point (such as a stone) that the operator can access from the original working position and the new machine position. Be aware that the accuracy of transferring a benched elevation depends on how stable the chosen reference point is. Using this method over multiple transfers may eventually introduce error.

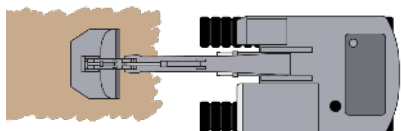

**Step 1:** Dig close to your machine.

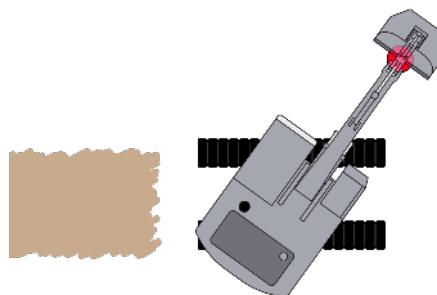

**Step 2:** Before moving your machine tracks, rotate and place the bucket (height tool point) on a sturdy point (stone) to use for reference.



**Step 3:** Press the "load/store height" button. A confirmation appears briefly.

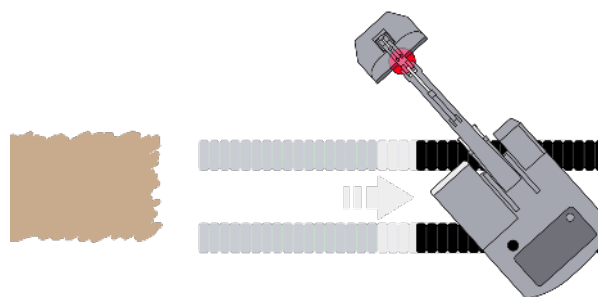

**Step 4:** Track your machine, taking care not to disturb the reference point. Place the bucket back on the reference point.



**Step 5:** Press the "load/store height" button. A confirmation appears briefly.

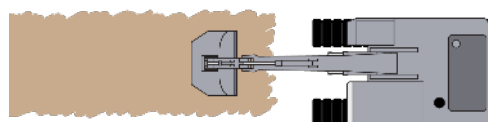

**Step 6:** Continue digging (while using the original bench).

## 5. Laser

The following workflows focus on the use of a laser:

- **Workflow 5.1.** Set up your laser (2D).
- **Workflow 5.2.** Bench laser height (2D).
- **Workflow 5.3.** Offset benched laser height (2D).
- **Workflow 5.4.** Align slope values of laser and bucket (2D).

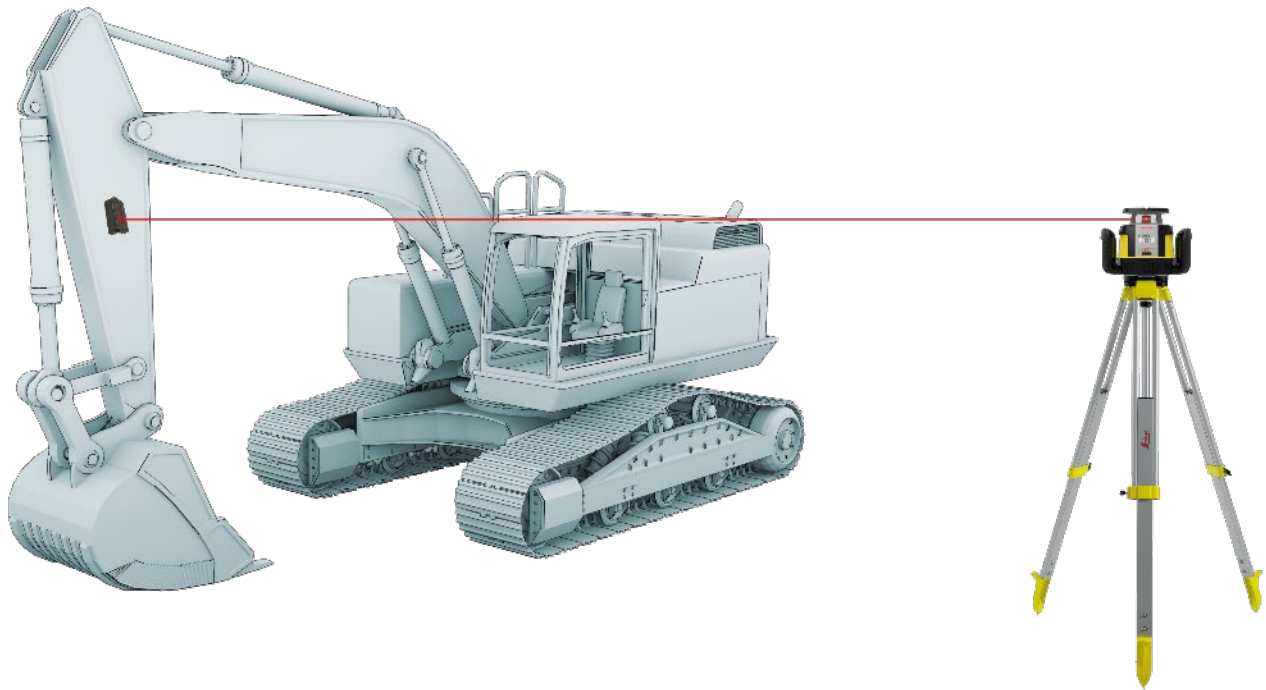

## Workflow 5.1. Set up your laser (2D)

Set up a machine control laser for optimum coverage of the job site. It must be out of traffic and any obstructions. Position laser and tripod at a height that can be reached by the laser receiver mounted on your machine. Adjust alignment of your laser to the site as needed.

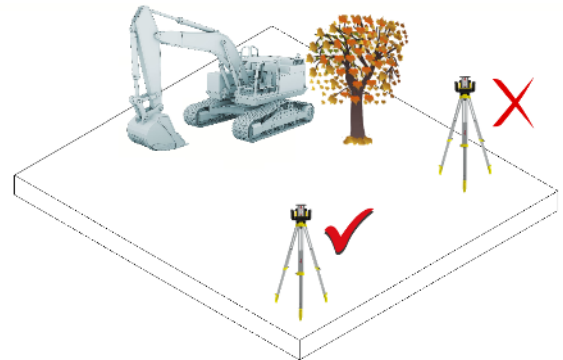
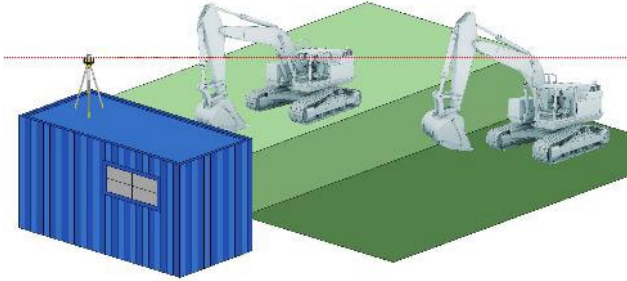

**Step 1:** Choose a good location for your laser:

- Since the laser beam is only used to bench when needed, it can be set to a height where multiple machines can access.

- No obstructions that could block or reflect the laser.

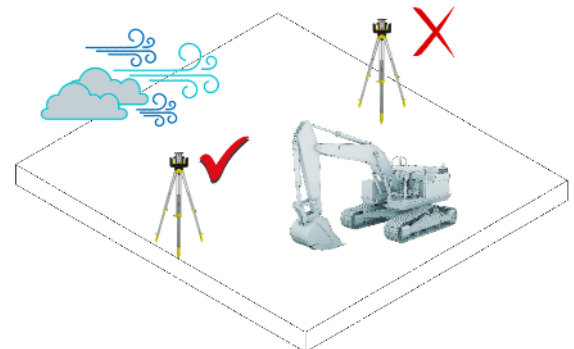
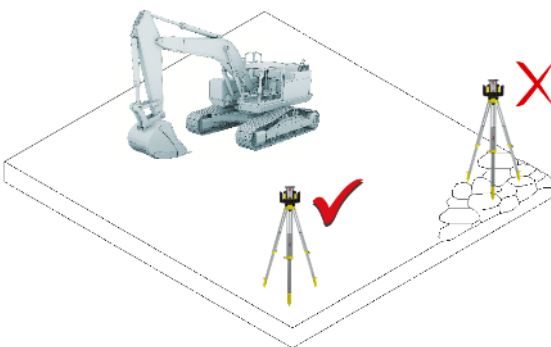

- Stable ground, so the tripod won't shift or settle (ground vibration can affect operation of the laser).

- Up-wind, in very dusty environment, so dirt is blown "away" from your laser.



**Step 2:** Check the tripod, then attach your laser.

- Make sure all tripod screws, bolts and nuts are tight.
- Place laser on tripod and tighten screw on underside to secure it to the laser tripod.
- If your tripod has chains, those chains should be slightly loose to allow for thermal expansion during the day.
- Secure your tripod in very windy conditions.

## Workflow 5.2. Bench laser height (2D)

Use laser for height benching to avoid compounding of small errors over multiple moving points (load/store).

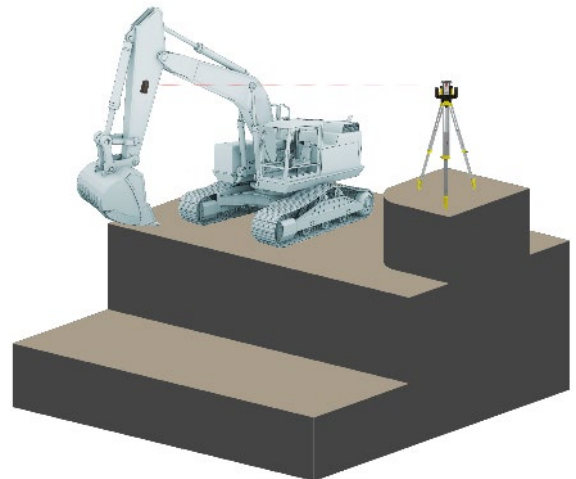
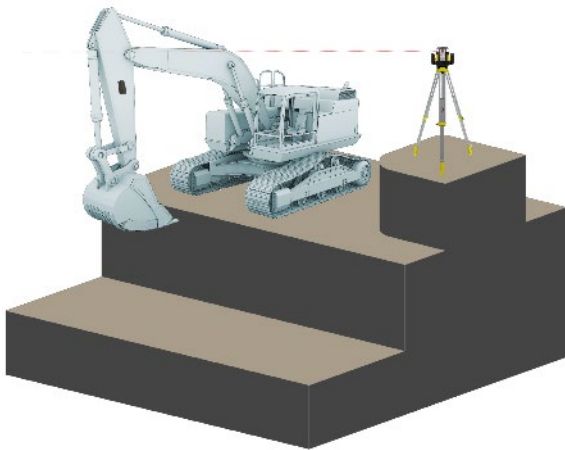

- For most efficient operation, set up the laser in a location where your machine avoids laser strike, until needed for benching.
- Once the laser strikes the laser sensor, and is accepted, the system takes over calculations.



- The system automatically calculates "0.00" on sensor, so the laser strike can be anywhere on LED window.

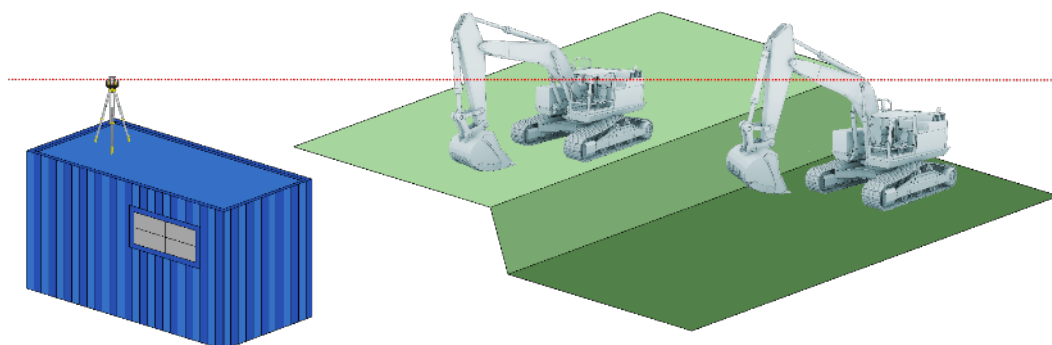

- It is not necessary to have the laser beam in the sensor LED window while digging. The laser can be set to a height that multiple machines can use as reference.

Continue to next page for how to bench laser height.

## Workflow 5.2. Bench laser height (2D), (Continued)

Follow these steps to bench height of your laser:

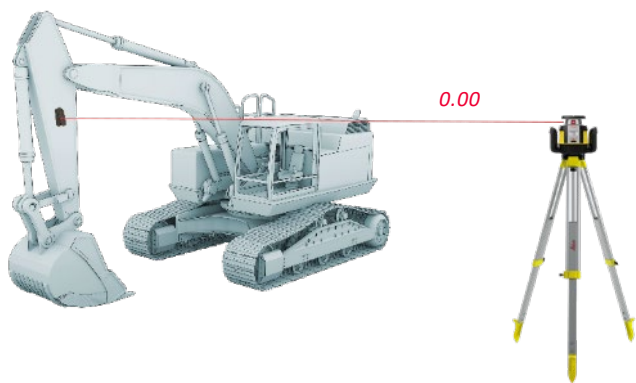

**Step 1:** Move the laser sensor into laser strike.



**Step 2:** Wait for a stable laser strike on sensor, then press the "bench 0" button. This will set height of laser beam as 0.00 reference.

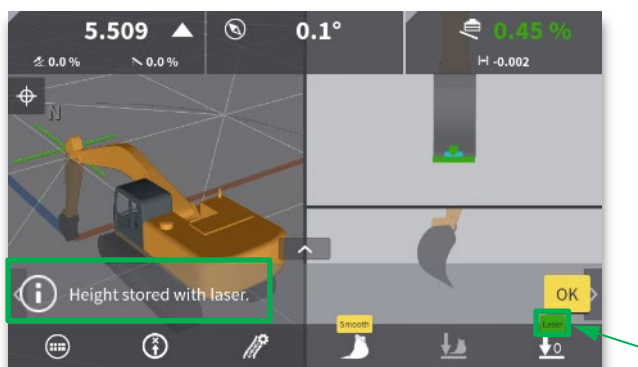

- A "Height stored with laser" confirmation and a green laser indicator appear briefly.

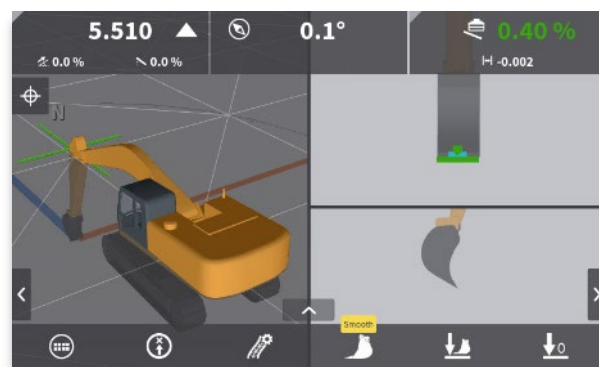

- The 2D system is now benched on the laser strike (You can now proceed to [Workflow 5.3.](#) to offset the benched laser height).

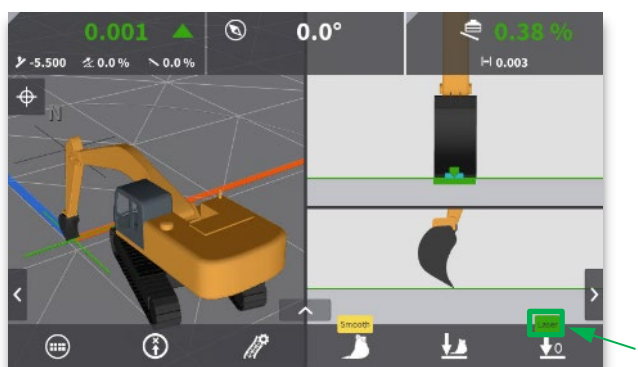

- If the laser strikes the laser sensor while digging, you may notice the green laser icon appear above the "bench 0" button. No new reference is applied, unless you press the "bench 0" button. Only press the "bench 0" button again if track position has moved/settled into the ground.

## Workflow 5.3. Offset benched laser height (2D)

When benching with a laser an additional height offset will be necessary to provide guidance to dig depth.

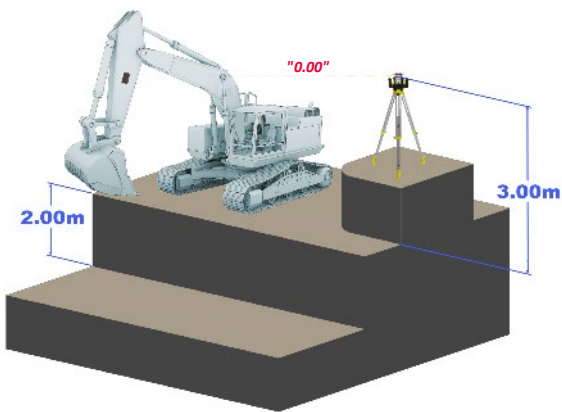

- Laser height offset = distance between laser beam and ground + distance between ground and target surface.

**Step 1:** Enter both X-slope and Y-slope values into the laser. Slope values entered into the laser **MUST** be the same as those entered into the panel.

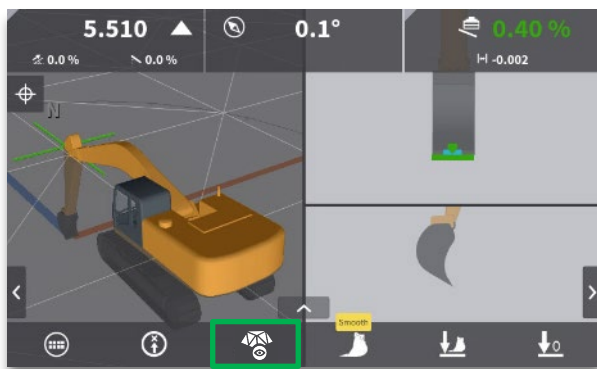

**Step 2:** Bench laser height ([Workflow 5.2.](#)), then press the model options button.

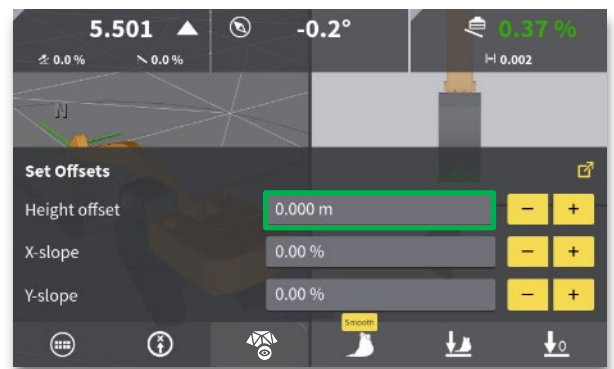

**Step 3:** Enter height offset values into the panel (press + or -). On-screen surface illustrations, and dig value, updates to reflect entered height offset.

Continue on next page.

## Workflow 5.4. Align slope values of laser and bucket (2D)

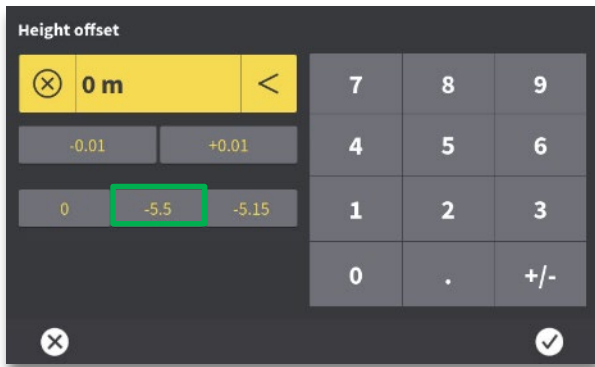

**Step 4:** Enter a specific value on the keypad. Alternatively, select -0,01m/+0.01m or one of the past 3 offsets. Press tick mark icon (OK). "Model Offsets" will return to the run screen.

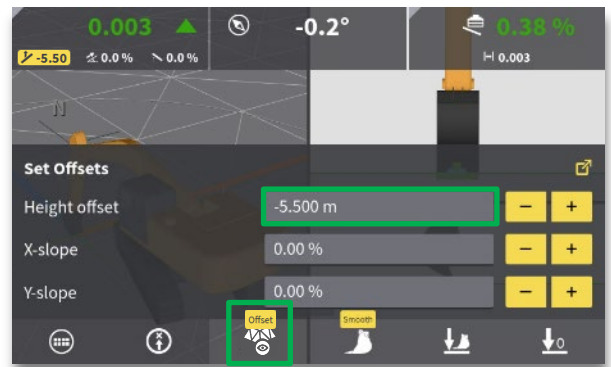

**Step 5:** Verify applied offset value. Press the model options menu to return to run-screen.

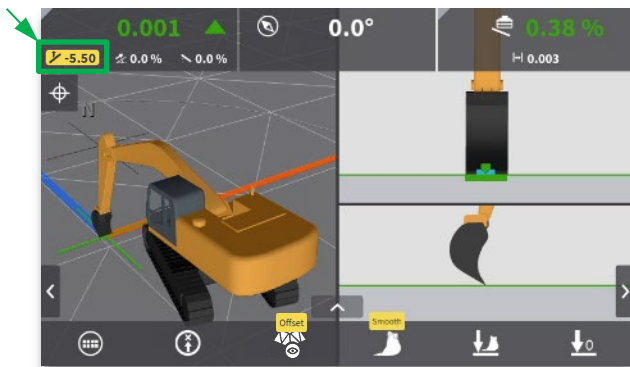

- Cut/fill values are provided to the offset, and applied height offset is displayed in the secondary value bar. The offset surface is also illustrated in the cross/long section views.

## 6. Tolerances

The following workflows focus on tolerances:

- **Workflow 6.1.** Change tolerance "colours" (2D/3D).
- **Workflow 6.2.** Change tolerances (2D/3D).
- **Workflow 6.3.** Change tolerance beep volume (2D/3D).

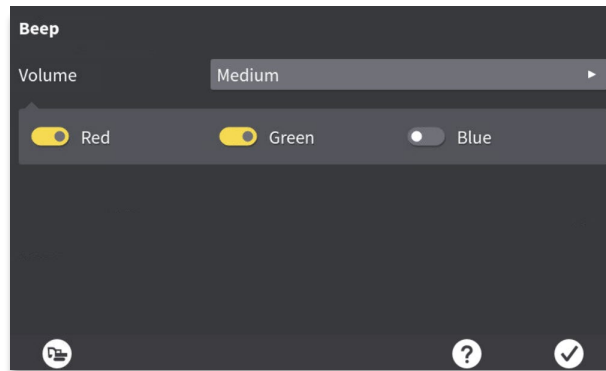
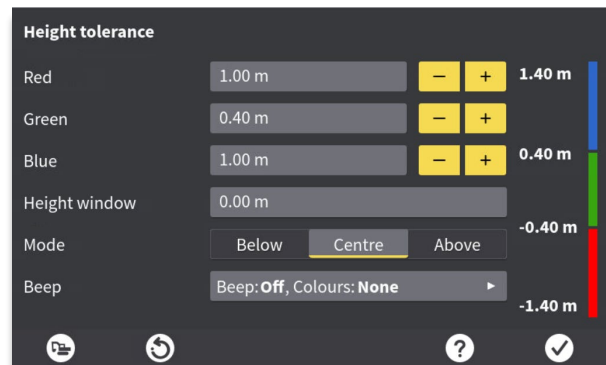

## Workflow 6.1. Change tolerance colours (2D/3D)

You can adjust the colours shown in the cut/fill window. There are 4 colour schemes to choose from. Note: on grade will always be represented by the colour green.

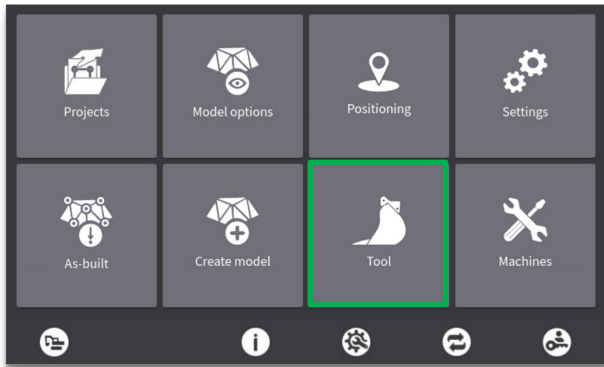

**Step 1:** Press the "Tool" menu.

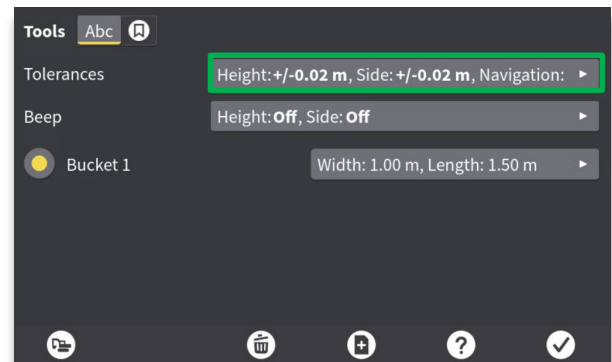

**Step 2:** Press the "Tolerances" menu.



**Step 3:** Select desired colour scheme (see illustration below for explanation).



**Step 4:** Press tick mark icon (exit).

### NOTE:

Left colour = **Fill**

Centre colour = **On grade**

Right colour = **Cut**

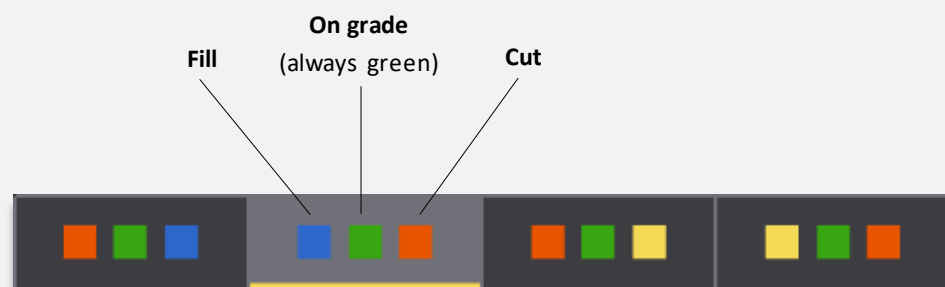

## Workflow 6.2. Change tolerances (2D/3D)

You can change the cross slope, height, and side tolerances to accommodate your job.



**Step 1:** Press the "Tool" menu.



**Step 2:** Press the "Tolerances" menu.



**Step 3:** Press the pencil icon next to the tolerances you want to change (in this case, the "Height tolerance").

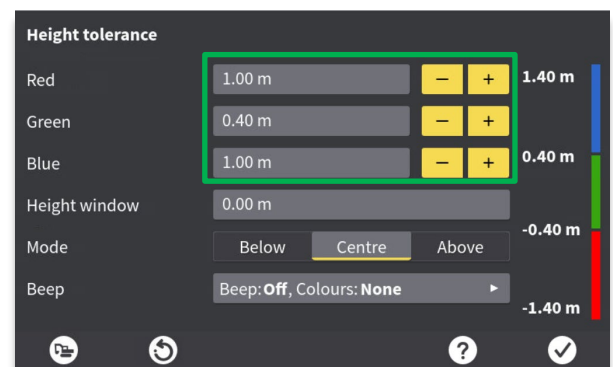

**Step 4:** Use the +/- buttons to increase or decrease tolerance for each field (fill, on grade and cut).

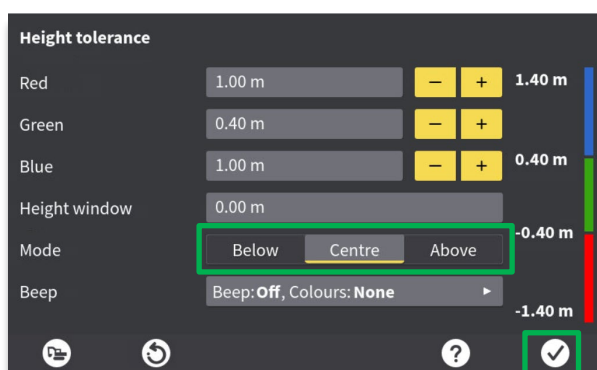

**Step 5:** Select the "Mode" (Below, Centre or Above). The mode defines where the green band is placed in relation to the target. Press tick mark icon (OK).

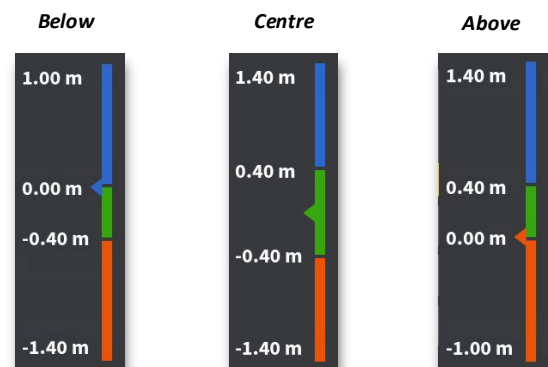

- **Below:** Green band below target.
- **Centre:** Green band below and above target.
- **Above:** Green band above target.

## Workflow 6.2 Change tolerances (2D/3D), (Continued)

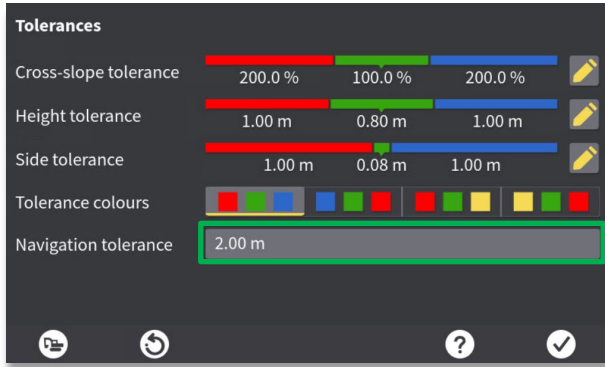

**Step 6:** The navigation tolerance is by default 2m. Press the grey square to change the value. The inserted value will affect when the software indicates that the tool point is on target and changes to green.

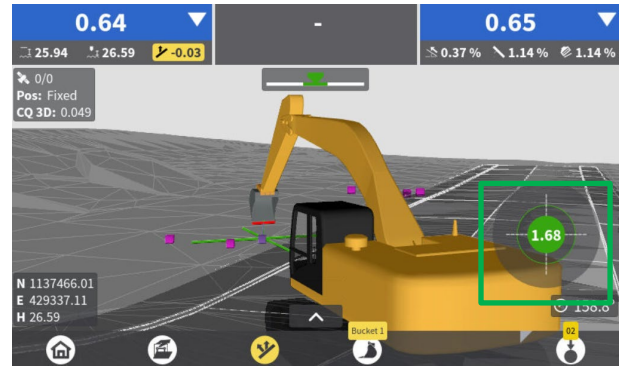

- The navigation bubble turns green when inside the navigation tolerance value.

## Workflow 6.3. Change tolerance "beep volume" (2D/3D)

Use the beep volume option to set how loud the control panel is to beep and when. This workflow describes change of beep volume for height and side tolerance.

Choose between **Off**, **Low**, **Medium**, and **High**.

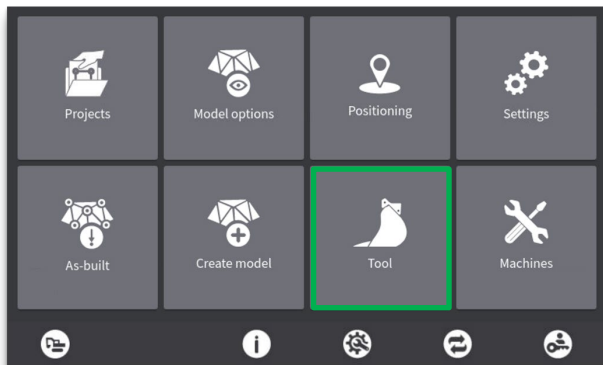

**Step 1:** Press the "Tool" menu.

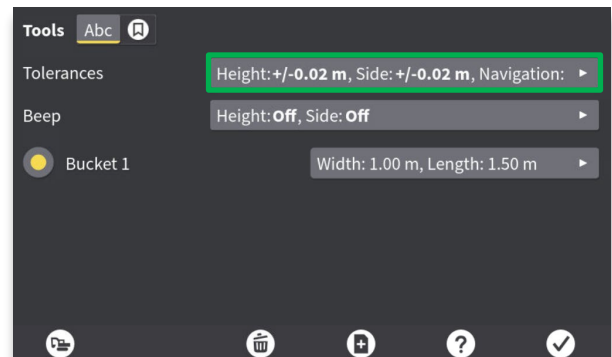

**Step 2:** Press the tolerance menu.



**Step 3:** Press the pencil icon next to the tolerances for which you want to change the beep volume (in this case, the "Height tolerance").

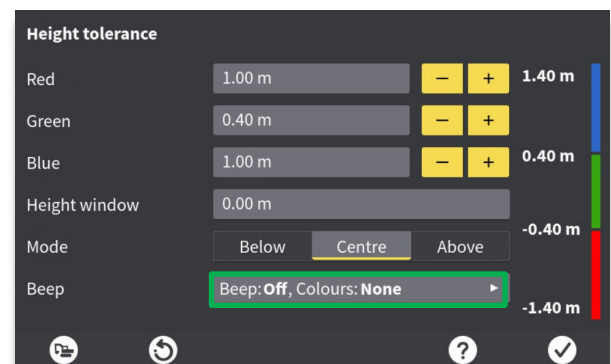

**Step 4:** Press the "Beep" menu.

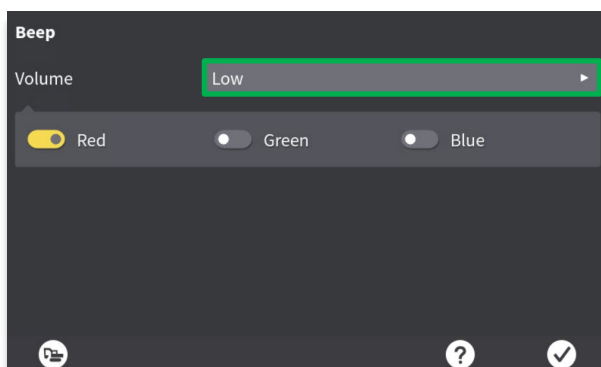

**Step 5:** Press the "Volume" menu.

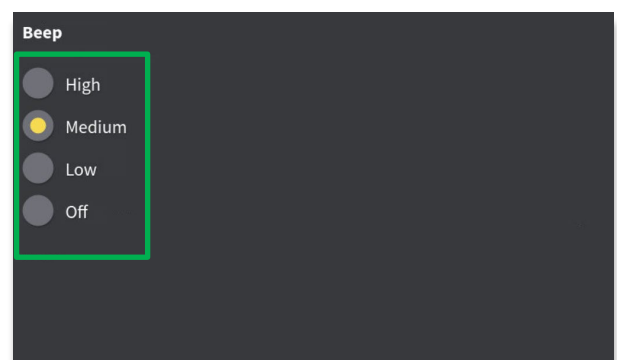

**Step 6:** Select desired volume.

## Workflow 6.3. Change tolerance "beep volume" (2D/3D), (Continued)

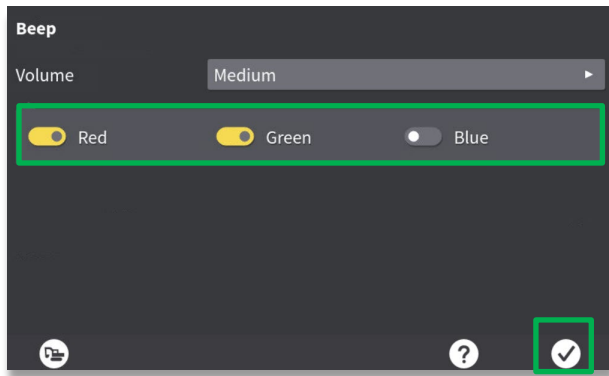

**Step 7:** Press the button corresponding to **fill, on grade** and **cut** to toggle beep options for each (ON or OFF).

Press tick mark to exit "Beep" menu.

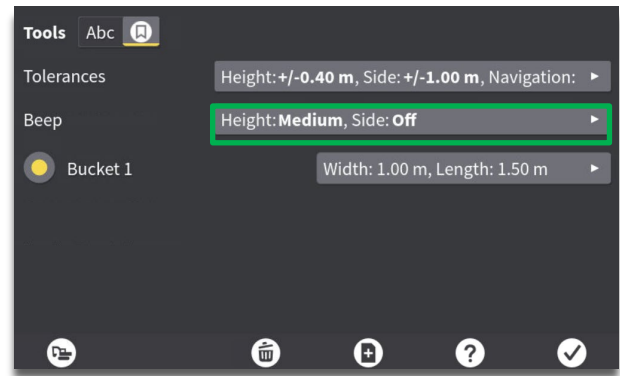

- The "Beep" menu is also available on the first page of the "Tool" menu for quick and easy customisation.

## 7. Auto mode

The following workflows focus on the auto modes (CoPilot and semi-automatic machine control):

- **Workflow 7.1.** Engage CoPilot auto tilt (2D/3D).
- **Workflow 7.2.** Engage CoPilot auto rotator (2D/3D).
- **Workflow 7.3.** Engage semi-automatic machine control (2D/3D).

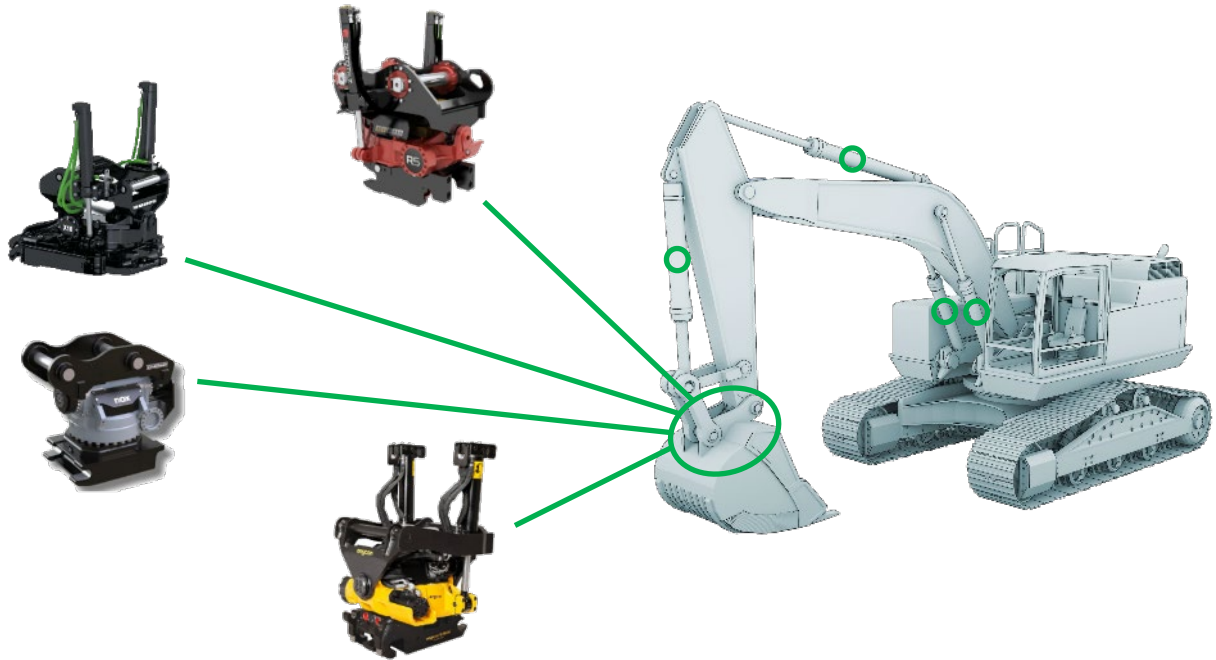

### NOTE:

Overview of auto modes:



- **No Icon** = Auto not configured
  - Select which functions should be controlled automatically from the bucket quick menu.

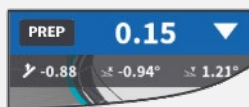

- **PREP** = Auto configured
  - Tap this icon to activate auto prepared mode.
  - This function can be configured to an external button.

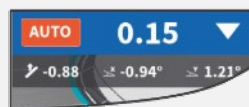

- **Red AUTO** = Auto prepared
  - When auto is prepared the system is ready for automatic assist of the configured functions.
  - Place the bucket inside the model boundaries and within the operational window height.
  - Apply pressure to stick hydraulics to engage automatics.

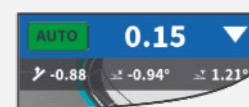

- **Green AUTO** = Auto engaged
  - Configured functions are currently being automatically controlled.

## Workflow 7.1. Engage CoPilot auto tilt (2D/3D)

CoPilot for tilt automatically tilts the bucket to match the design surface below cutting edge. With CoPilot auto tilt engaged, you can manually control the rotator +/- 45 degrees. If the bucket is rotated more than 45 degrees, you will not be able to go into green AUTO. It is recommended to use "closest to" height tool point ([Workflow 4.6.](#)) when using CoPilot auto tilt.



**Step 1:** Press the bucket icon.

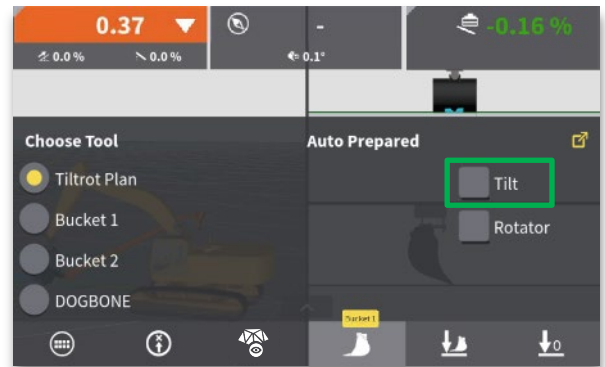

**Step 2:** Press the "Tilt" box in the "Auto Prepared" section.

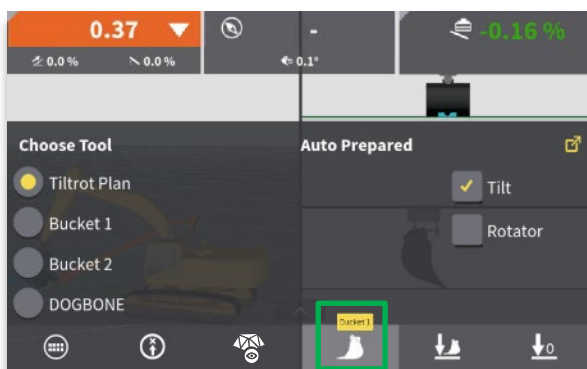

**Step 3:** Press the bucket icon to close the menu.

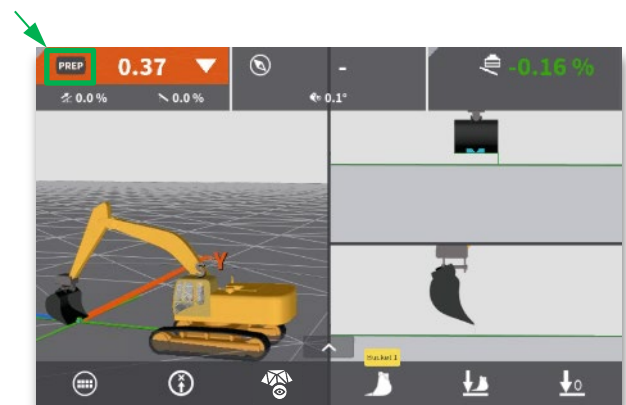

**Step 4:** Press the "PREP" button to activate CoPilot prepared mode (can be configured to an external button).



• The "PREP" button changes to red "AUTO".

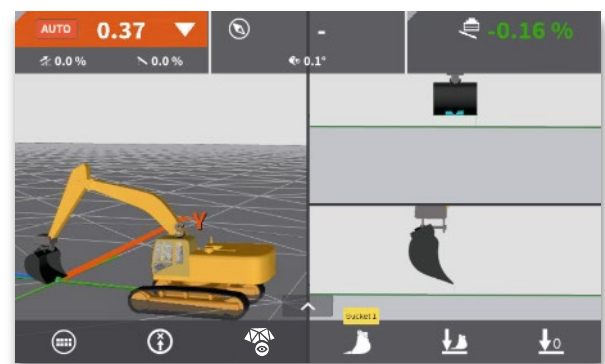

**Step 5:** Place the bucket above desired slope.

## Workflow 7.1. Engage CoPilot auto tilt (2D/3D), (Continued)

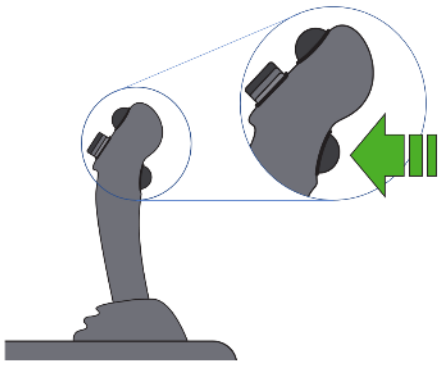

**Step 6:** Activate the tilt rotor auto-button, and the system automatically adjusts to design slope.

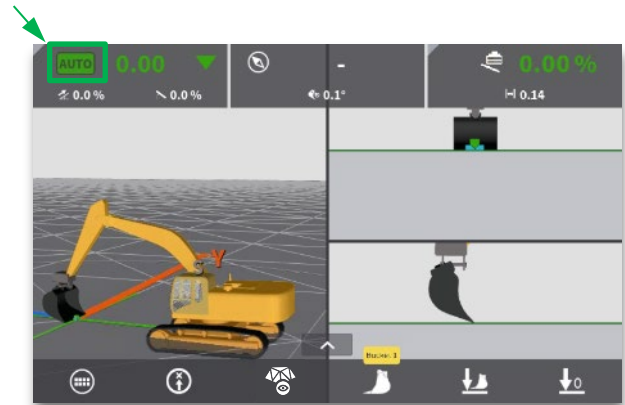

- The "AUTO" button turns green, and the system maintains any change in design slope below the bucket.

## Workflow 7.2. Engage CoPilot auto rotator (2D/3D)

CoPilot for rotator automatically rotates the bucket to match design rotation. It is recommended to use “closest to” height tool point ([Workflow 4.6.](#)) when using CoPilot auto rotator.



**Step 1:** Press the bucket icon.

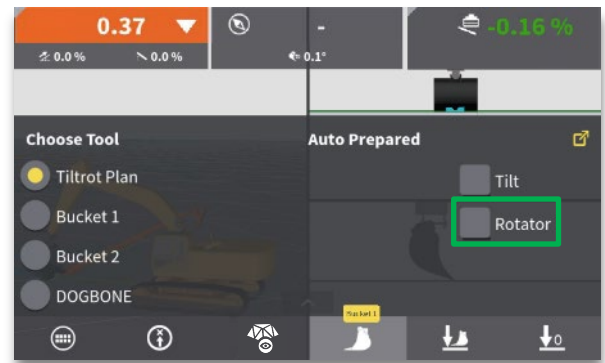

**Step 2:** Press the "Rotator" box in the "Auto Prepared" section.

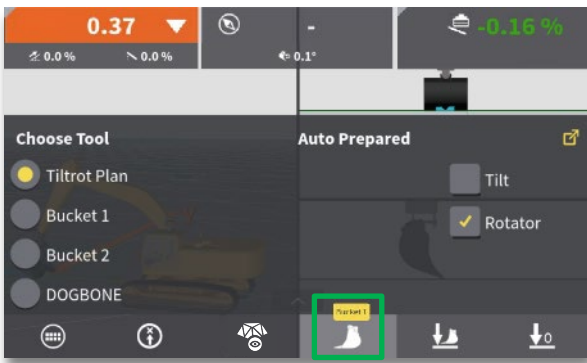

**Step 3:** Press the bucket icon to close the menu.



**Step 4:** Press the "PREP" button to activate CoPilot prepared mode (can be configured to an external button).



- The "PREP" button changes to red "AUTO".

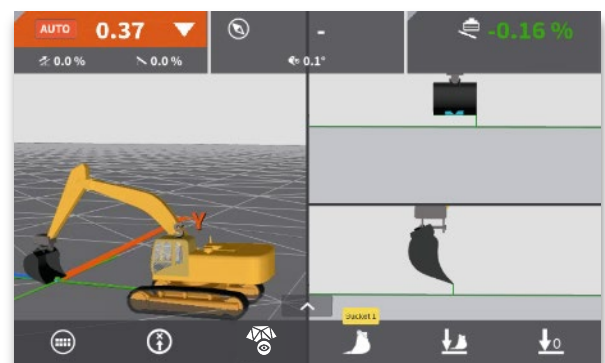

**Step 5:** Place the bucket above desired slope.

## Workflow 7.2. Engage CoPilot auto rotator (2D/3D), (Continued)

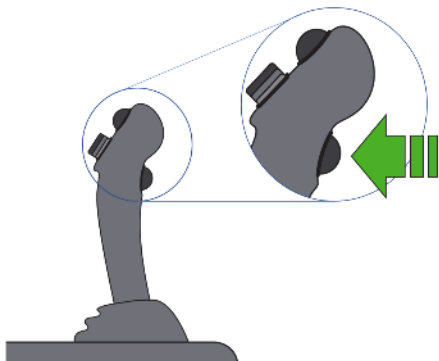

**Step 6:** Activate the tilt rotor auto-button, and the system automatically adjusts to design rotation.

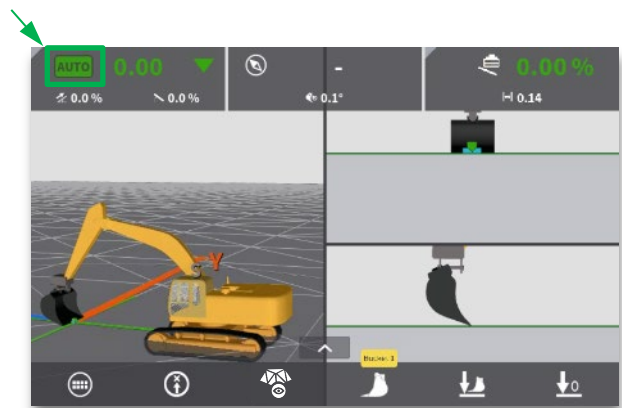

- The "AUTO" button turns green, and the system rotates the bucket to match design grade.

### NOTE:

- This CoPilot functionality only rotates the bucket to 0 degrees rotation.

## Workflow 7.3. Engage semi-automatic machine control (2D/3D)

It is recommended to use "closest to" height tool point ([Workflow 4.6.](#)) when using semiautomatic excavator functions.

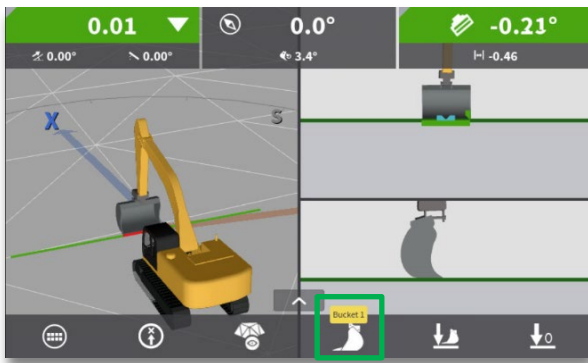

**Step 1:** Press the bucket icon.

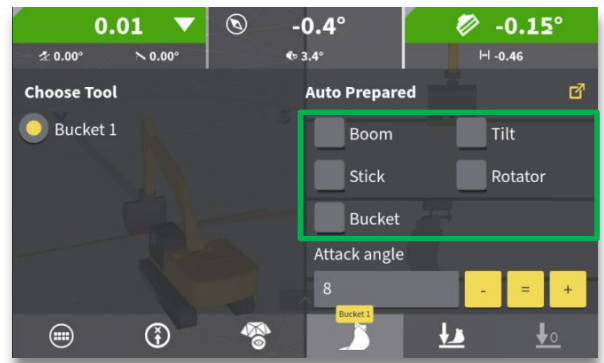

**Step 2:** Press the boxes for the functions that should be controlled automatically.

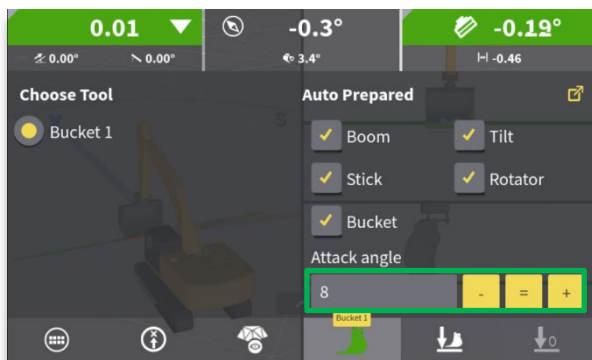

**Step 3:** Adjust "Attack angle" (if desired) by using the +/- keys or pressing the value field.

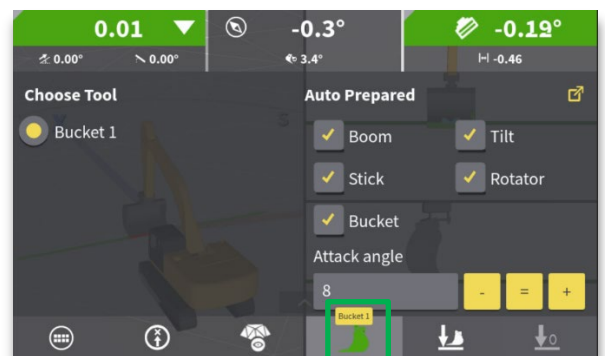

**Step 4:** Press the bucket icon to close the menu.



**Step 5:** Press the "PREP" button to activate semi-automatic prepared mode (can be configured to an external button).



- The "PREP" button changes to flashing red "AUTO".

## Workflow 7.3. Engage semi-automatic machine control (2D/3D), (Continued)

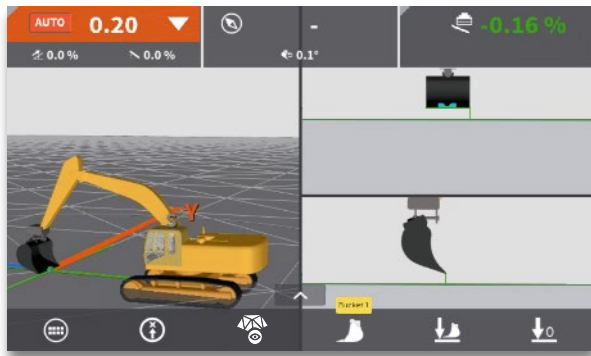

**Step 6:** Place bucket inside model boundaries, and within operational height window (which is 30cm.)

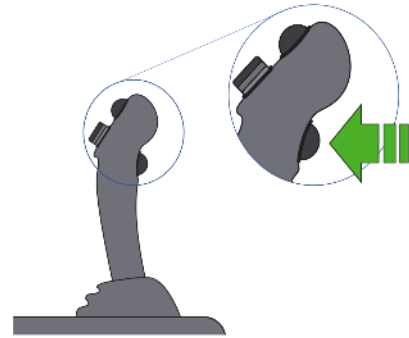

**Step 7:** If a tilt rotor interface is used, activate (and hold) the tilt rotor auto-button.

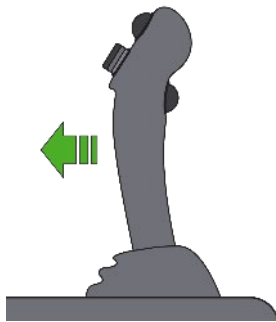

**Step 8:** Apply pressure to stick hydraulics.

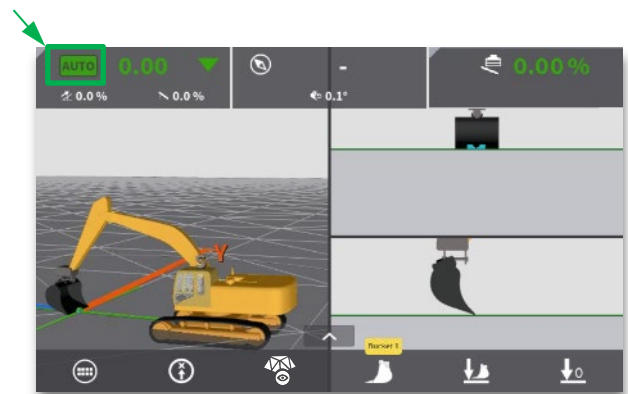

**Step 9:** The "AUTO" button turns green, and the system activates selected functions to move cutting edge towards the model below. Apply moderate stick speed to let the system keep on target.

### NOTES:

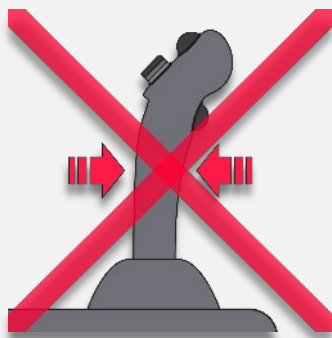

- You can stop automatic movement by letting go of the stick.

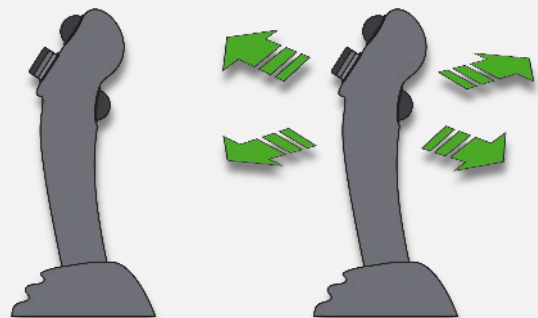

- You can override automatic movement by manually controlling any of the auto prepared functions.

## 8. Projects and models

The following workflows focus on projects and models:

- [Workflow 8.1.](#) Synchronize files (3D).
- [Workflow 8.2.](#) Find your project and models (3D).
- [Workflow 8.3.](#) Select and use references from run-screen (3D).
- [Workflow 8.4.](#) Create a "baseline" model (3D).
- [Workflow 8.5.](#) Create a "dual slope" model (3D).



## Workflow 8.1. Synchronise files (3D)

Files can be synchronised to and from ConX, a USB key and iCON site both manually and automatically. This way you can send and receive files between machine and office. You need a valid ConX license and a USB key to perform the synchronisation.

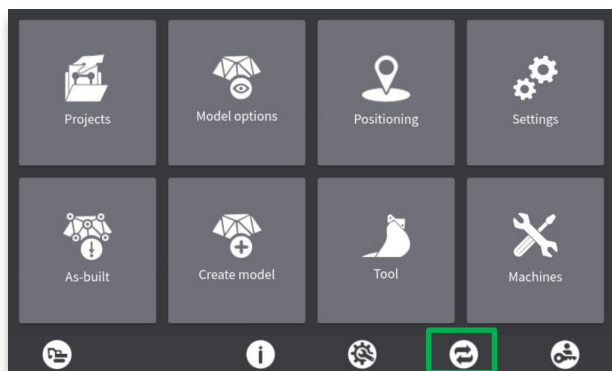

**Step 1:** Press the synchronisation button.

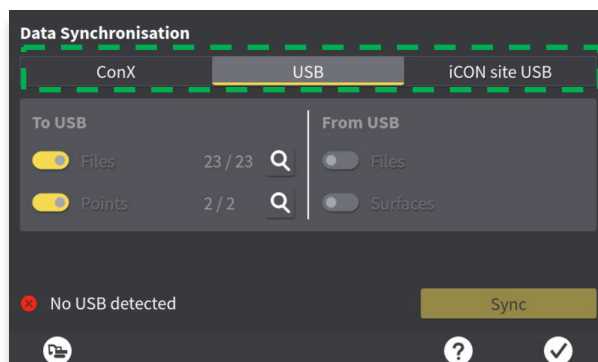

- Selection of possible synchronisation methods. “USB” is only selectable with an inserted USB key in the panel.

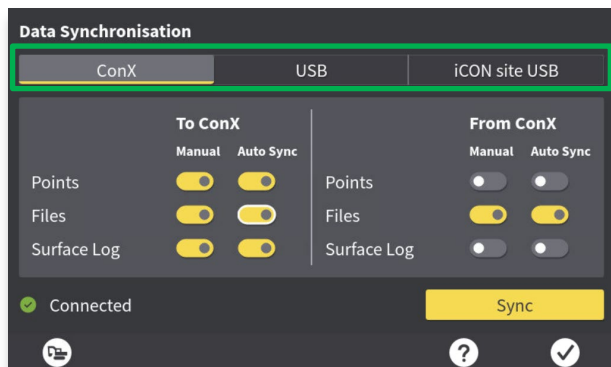

**Step 2:** Select desired synchronisation method. ConX is connected and therefore available for sync.

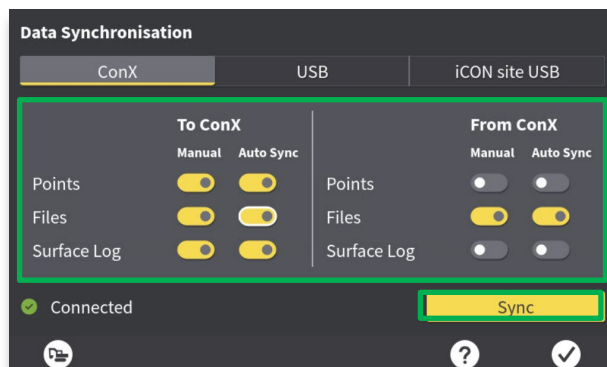

**Step 3:** Select which data type under “To ConX” and “From ConX” to synchronise either manually or automatically. Press “Sync” to start manual synchronisation.

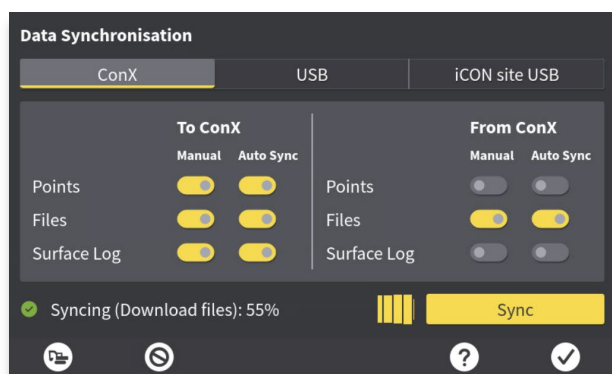

- Synchronisation progress will be indicated on the screen. If you want to continue working while ConX syncs, you can press the machine icon to return to run screen or any other page (a pop-up message will inform you when the sync is completed).

## Workflow 8.2. Find your project and models (3D)

Multiple models can be loaded for a project, and several references can be made available for selection in the in the command centre. The command centre can be accessed from the run screen, or in "Projects" menu. If you already have all the necessary files loaded for your project, skip ahead to "Step 4".

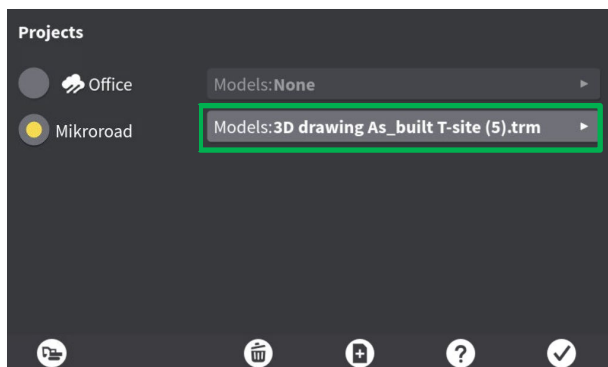

**Step 1:** Press the menu next to the project you are using, to view model details.

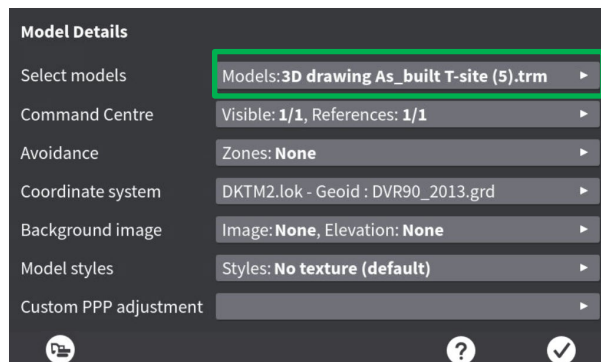

**Step 2:** Press the "Select models" menu, to access available models.

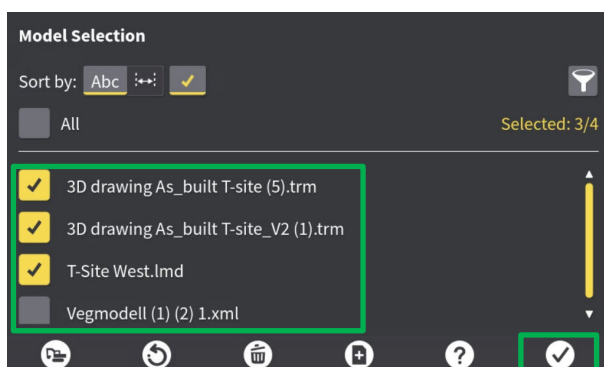

**Step 3:** Select models to be available in the command centre. Press the tick mark icon (OK) to return to previous menu.

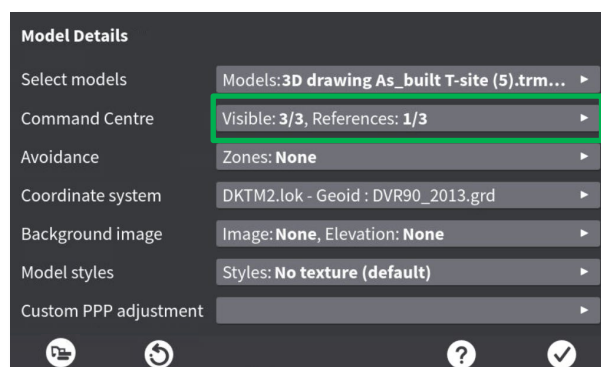

**Step 4:** Press the "Command centre" menu, to access available models. You can also access the command centre from the run screen ([Workflow 8.3](#)).

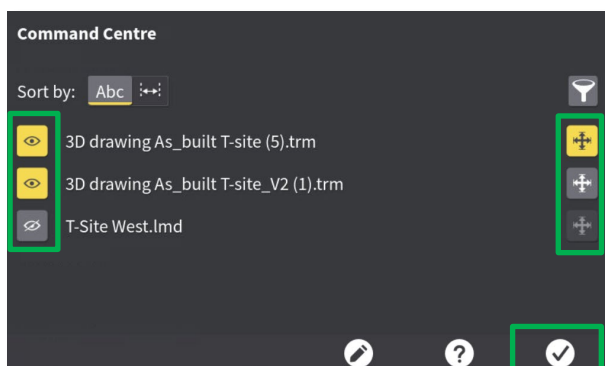

**Step 5:** Set which references that should be visible and available for selection in the run screen. Press the tick mark icon (OK) to return to previous menu.

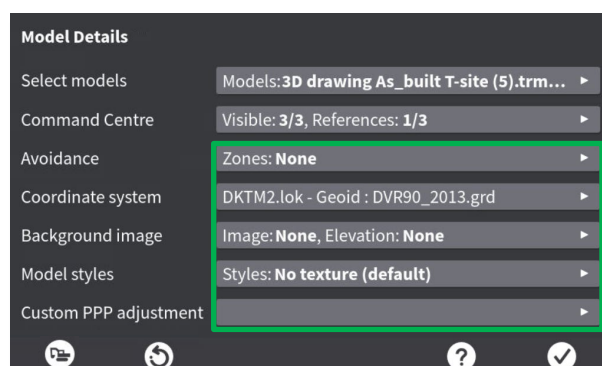

**Step 6: (Optional)** Select Avoidance zones, Coordinate system, Background image, Model styles and Custom PPP adjustment in these menus. Press tick mark icon to apply changes.

## Workflow 8.2. Find your project and models (3D), (Continued)

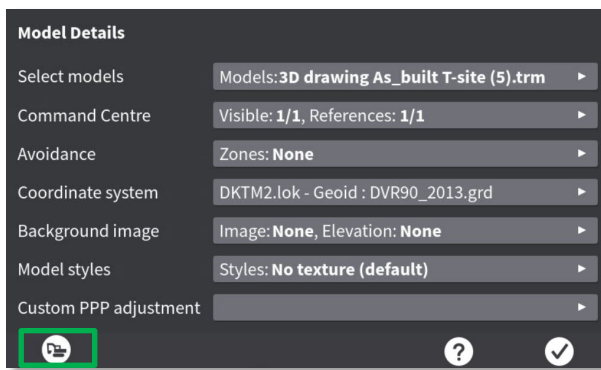

**Step 7:** Press the excavator icon to apply changes and return to run screen.

## Workflow 8.3. Select and use references from run-screen (3D)

Available models must be loaded in "Select models" menu ([Workflow 8.2](#)). Once this is done, you can easily switch between models in the run screen. You can make multiple references from multiple models available for selection in the run screen.

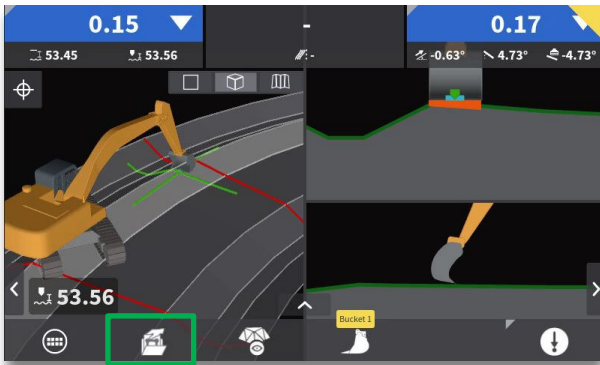

**Step 1:** Press the "Command centre" menu.

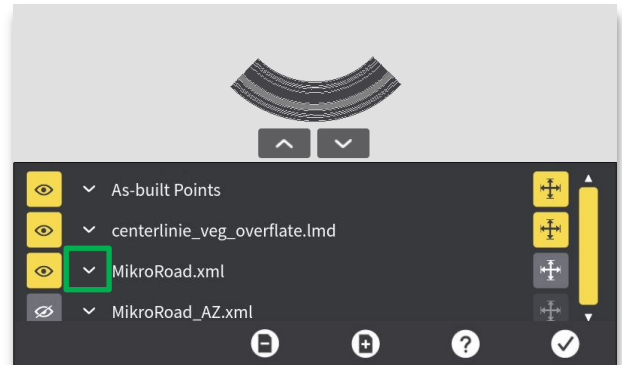

- Press the "down arrow" to view references within a model.

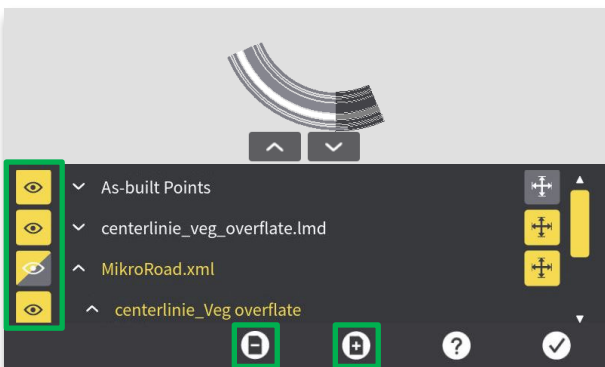

**Step 2:** Select the models that contain the references you want to make visible in the run screen. Press plus/minus icons to add or remove models in the command centre.

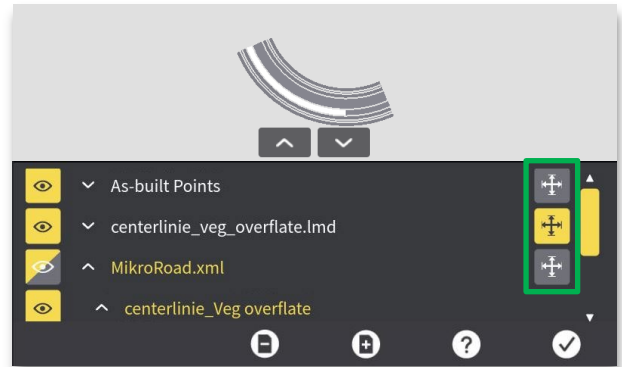

**Step 3:** Select which models you want to make referential in the run screen. **NOTE:** models cannot be made referential in the run screen if visibility is turned OFF (Step 2).

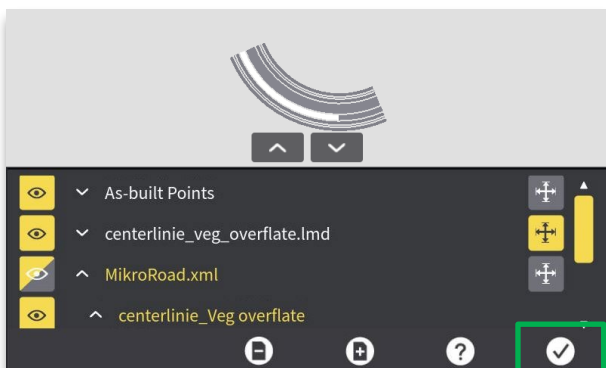

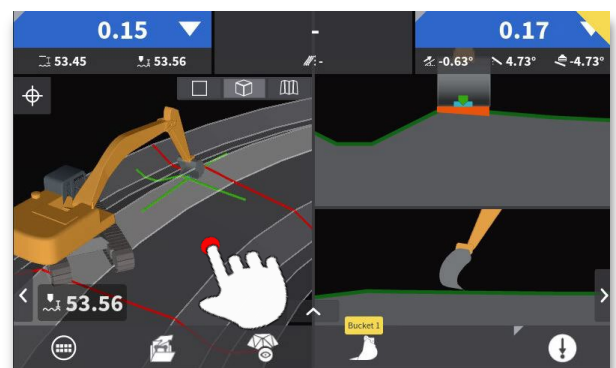

**Step 4:** Press the tick mark icon (OK) to return to the run screen.

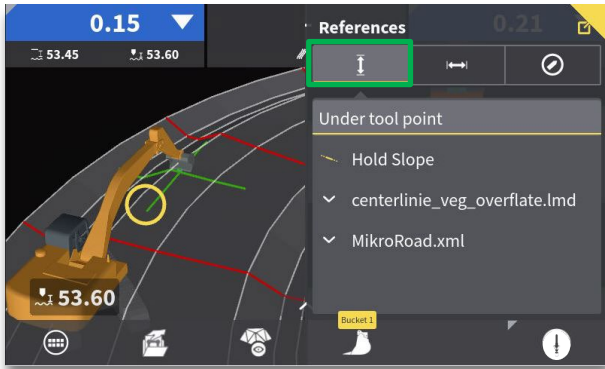

**Step 5:** Press and hold on the model to see the "References" menu.

## Workflow 8.3. Select and use references (3D), (Continued)



**Step 6:** Press  icon to view available height references (if not already highlighted).

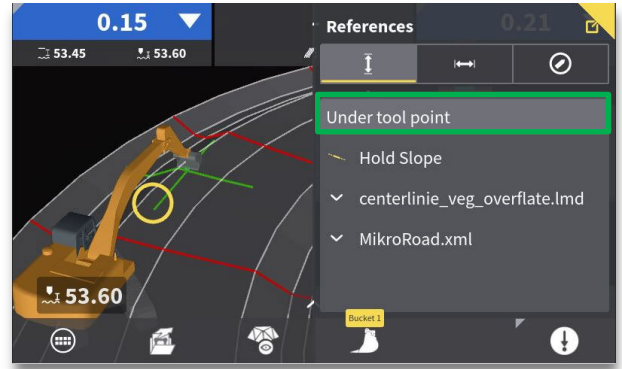

**Step 7:** By default, the height reference is “under tool point” and the side reference “none”. For other selections, please refer to Chapter 9.

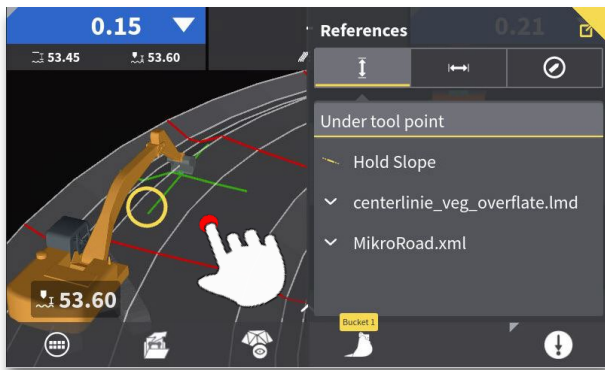

**Step 8:** Tap anywhere in the plan view to exit the “References” menu.

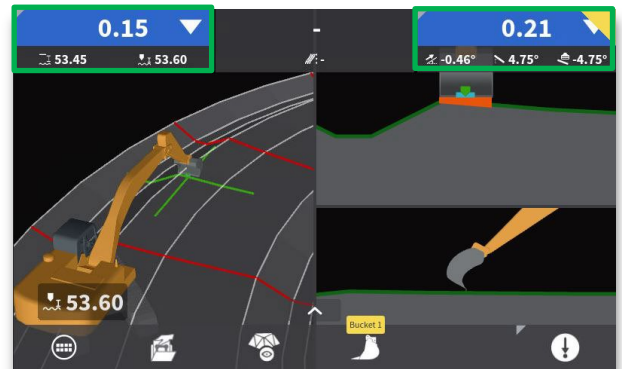

- The selected reference will be represented by a bold green line. Cut/fill will be provided to this reference and design cross-slope and long slope will update to reflect the height reference selected.

## Workflow 8.4. Create a baseline model (3D)

You can create a baseline model using your machine with MC1 by using existing logged points or logging new ones. Baseline models are used for drainage, sewage, trench for curbs and anything you would use a stringline for. There is no limit to the number of elements used to create the baseline model. In this example we will create a new model by logging new points on the go.

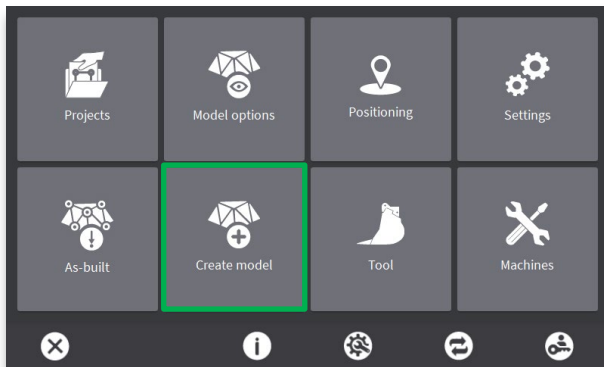

**Step 1:** Press the “Create model” menu.

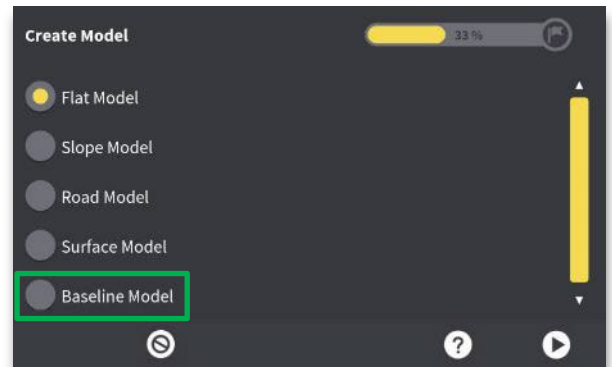

**Step 2:** Select “Baseline model”.

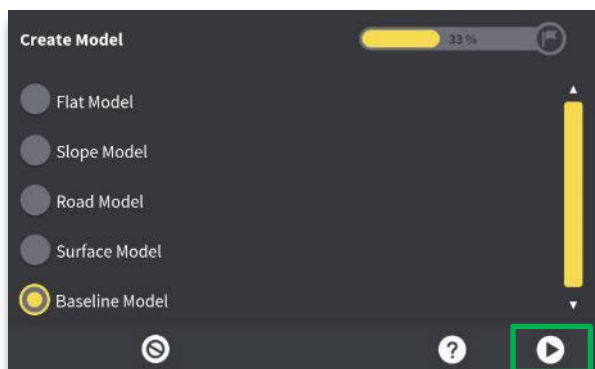

**Step 3:** Press right arrow (next).

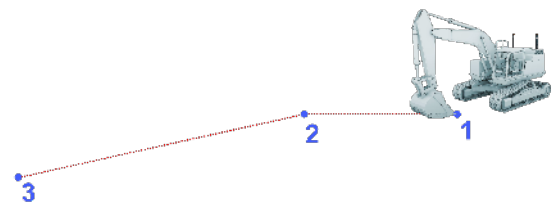

**Step 4:** Place your tool point on the first point of the desired baseline.

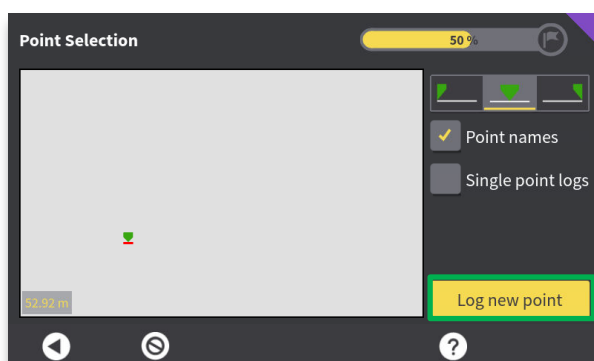

**Step 5:** Press the “Log new element” button.

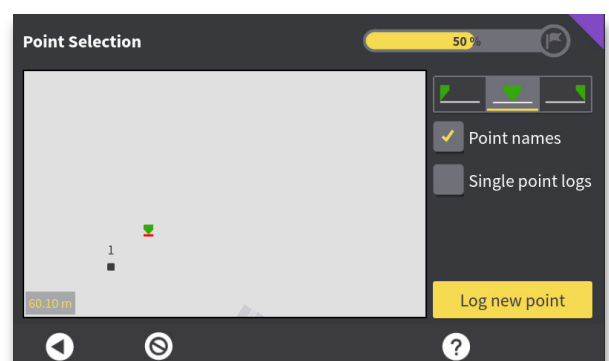

**Step 6:** The number 1 is assigned to the first point. Repeat steps 4-5 for the remaining points in the desired baseline.

## Workflow 8.4. Create a baseline model (3D), (Continued)

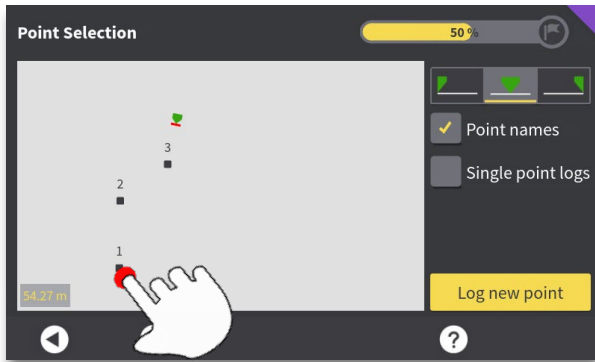

**Step 7:** Press and hold on the point where your project begins.

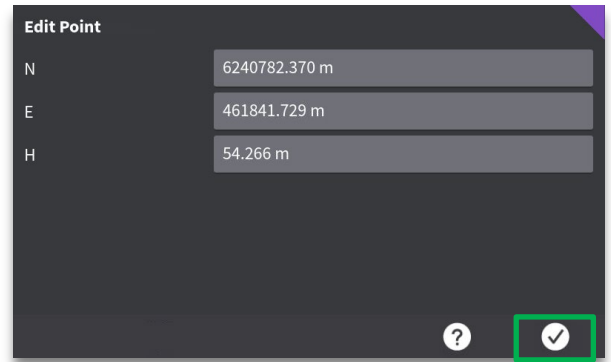

**Step 8:** Edit point values (if desired) and press tick mark icon (OK). Editing this point anchors it from adjustment in steps 13-16.

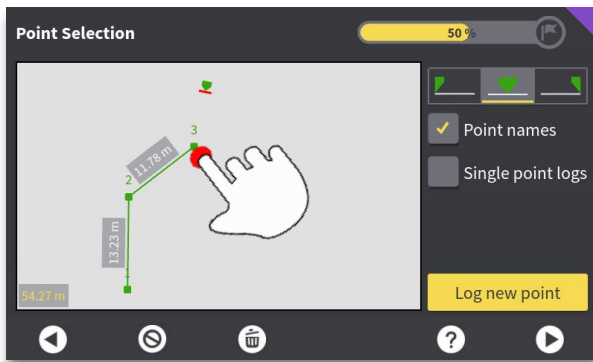

**Step 9:** Connect the points by tapping each point individually. This creates the baseline.



**Step 10:** Press right arrow (next).

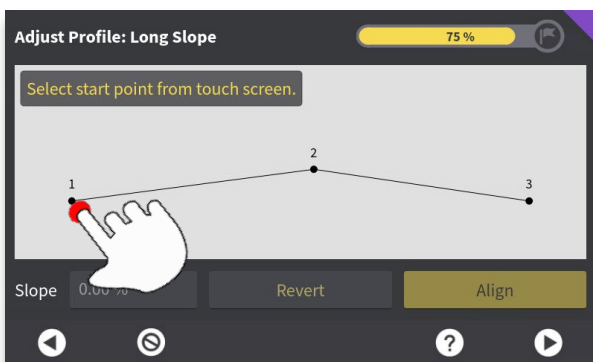

**Step 11:** Select beginning of baseline long slope by tapping the desired point.



**Step 12:** Select end of baseline long slope by tapping the desired point.

## Workflow 8.4. Create a "baseline" model (3D), (Continued)

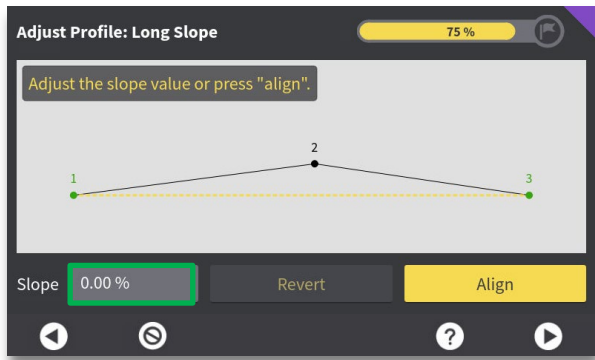

**Step 13:** Adjust the long slope per your project specifications by tapping the slope window.

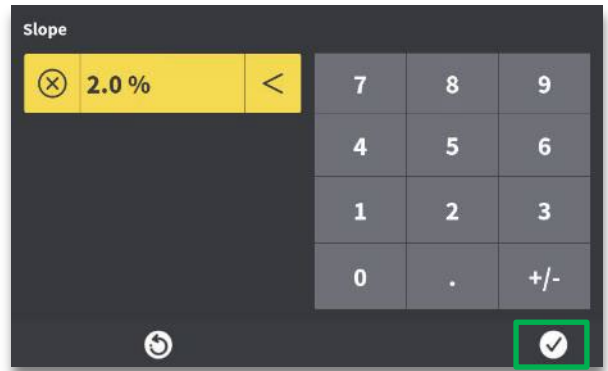

**Step 14:** Enter the desired long slope value and press tick mark icon (OK).

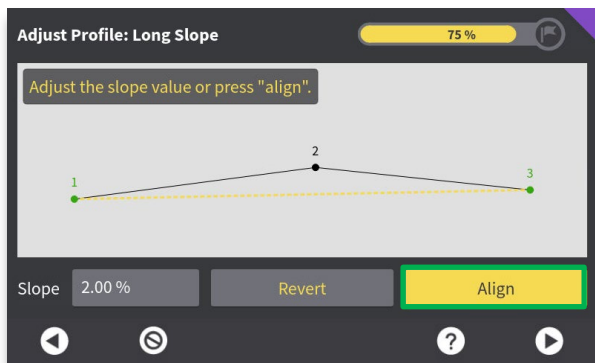

**Step 15:** Press "Align" to align your long slope to the entered value beginning at the point we adjusted in step 8.



**Step 16:** Press right arrow (next).

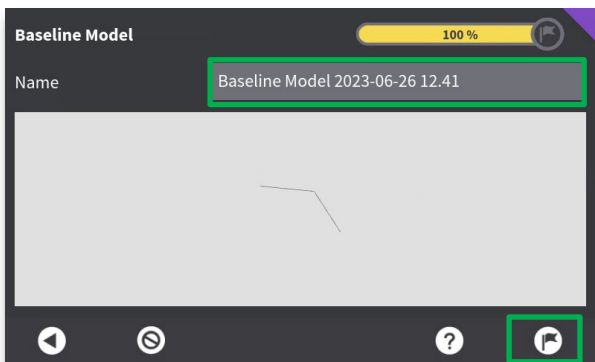

**Step 17:** Rename the baseline model (if desired) and press the flag icon (finish).

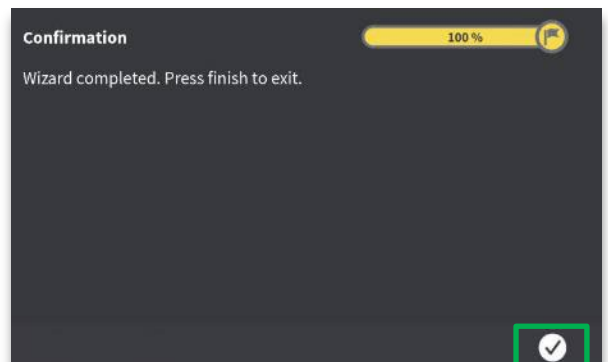

**Step 18:** Press tick mark icon (OK).

## Workflow 8.4. Create a "baseline" model (3D), (Continued)

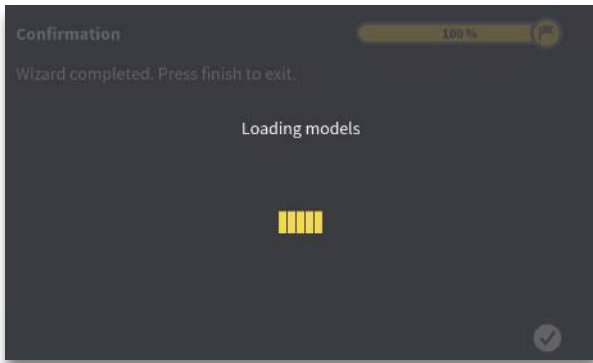

- The baseline model will load automatically.

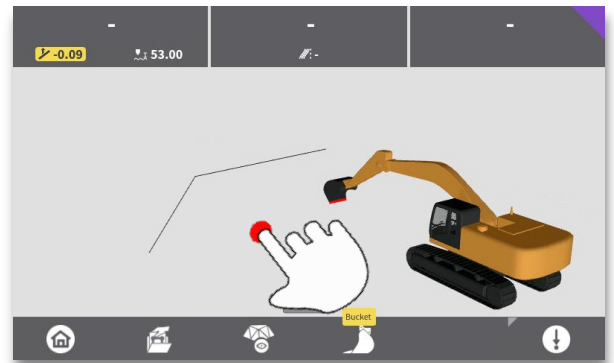

- Step 19:** Press and hold on the plan view to access your available references.

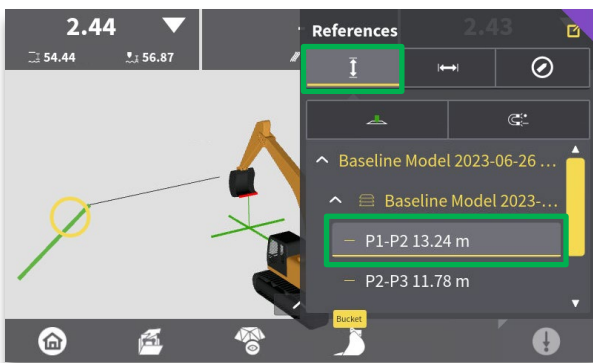

- Step 20:** Set the height reference to the first segment.

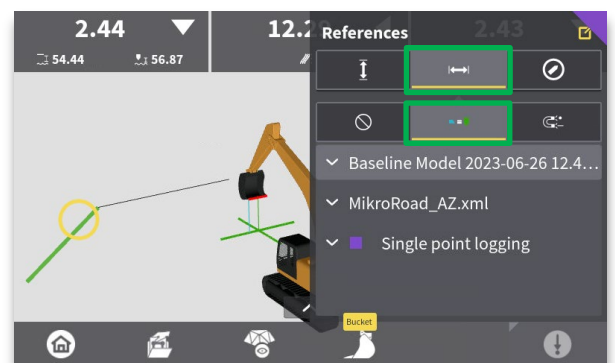

- Step 21:** Set the side reference to "Follow height".

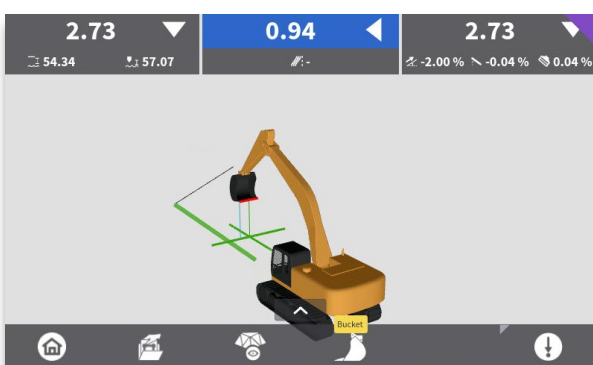

- Step 22:** You are now ready to dig to the baseline model.

## Workflow 8.5. Create a dual slope model (3D)

Grading parking lots or any surface with 1 or 2 slopes.

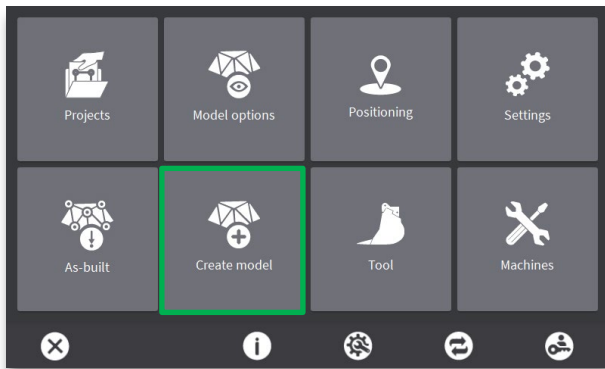

**Step 1:** Press the “Create model” menu.

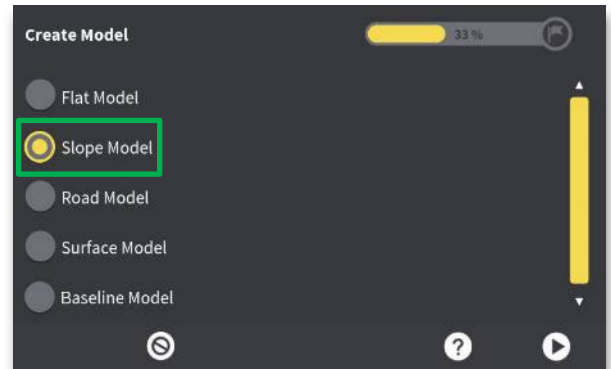

**Step 2:** Select “Slope model”.

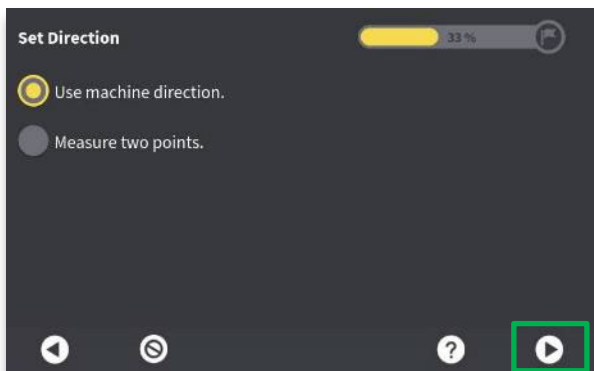

**Step 3:** Select “Use machine direction”. Press right arrow (next).



**Step 4:** Point your boom to the desired X direction.

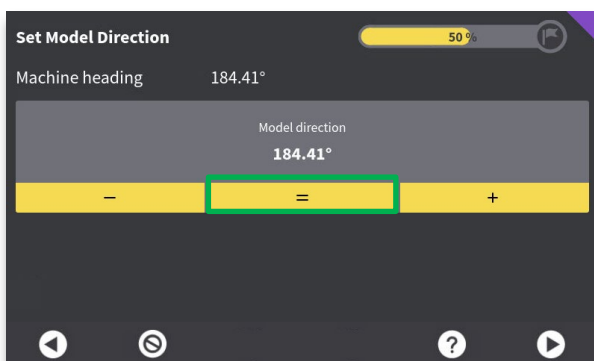

**Step 5:** Press = (equal sign).

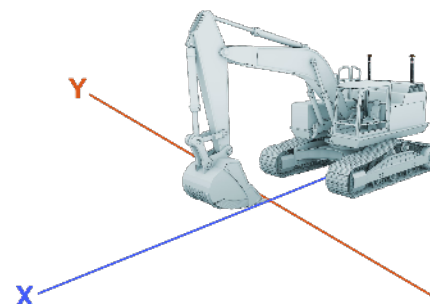

- The X direction will be aligned with the direction of the boom.

## Workflow 8.5. Create a dual slope model (3D), (Continued)

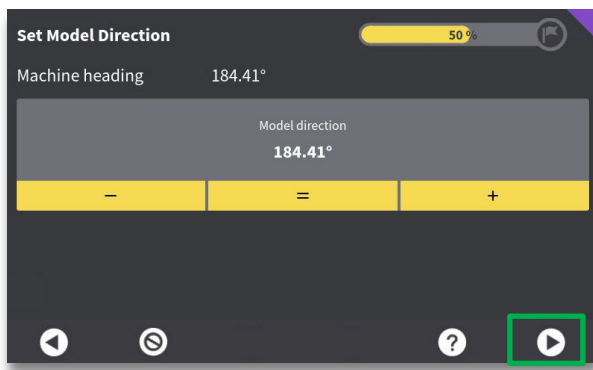

**Step 6:** Press right arrow (next).

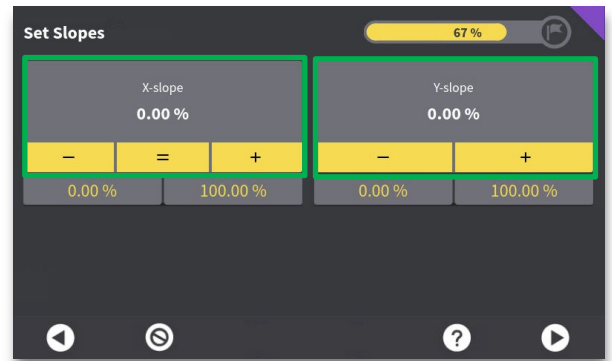

**Step 7:** Set X-slope and Y-slope to desired values.

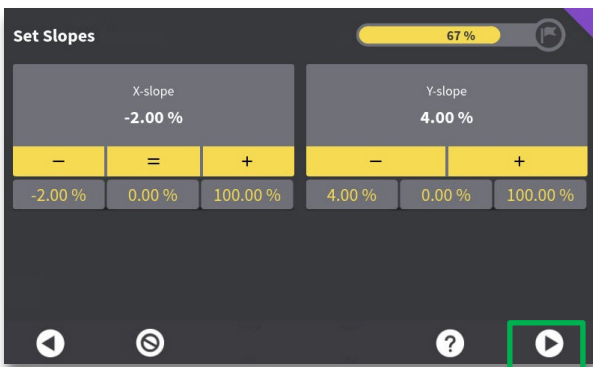

**Step 8:** Press right arrow (next).

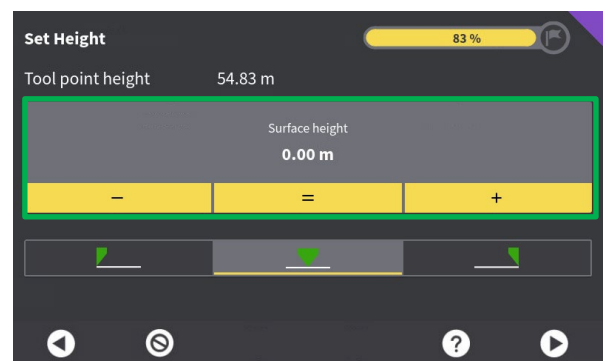

**Step 9:** Set surface height to desired elevation. If you want to use a tool point as reference, make sure you have selected the correct tool point, then press the equal sign.

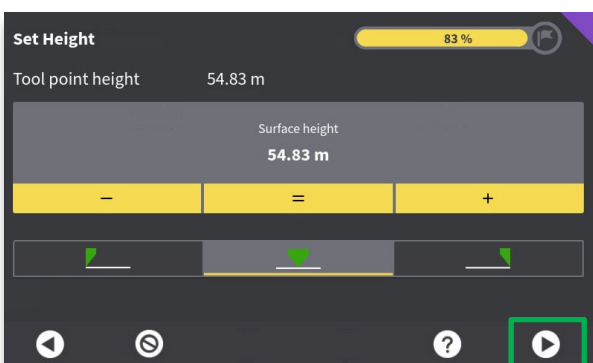

**Step 10:** Press right arrow (next).

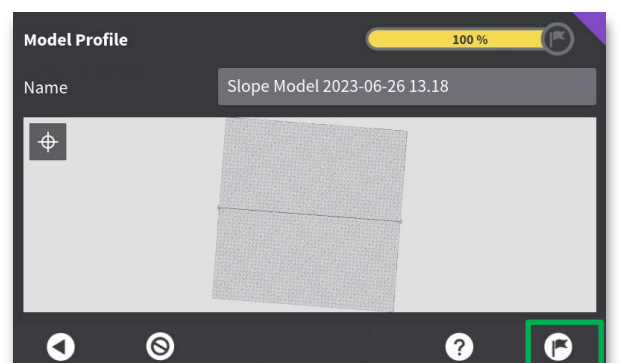

**Step 11:** Change the model's name (if desired) and press flag icon (finish).

## Workflow 8.5. Create a dual slope model (3D), (Continued)



**Step 12:** Press tick mark icon (OK).

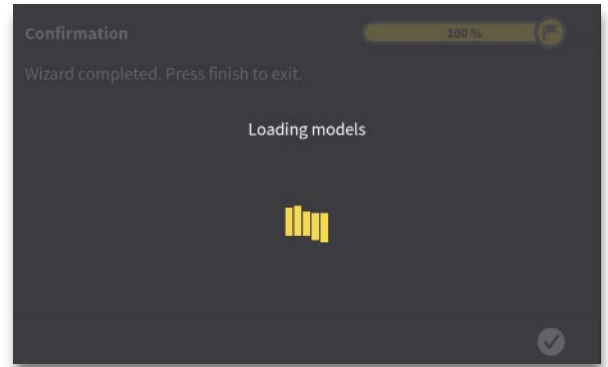

- The slope model will load automatically.



**Step 13:** You are now ready to dig to the model you have just created.

## 9. References

The following workflows focus on references:

- **Workflow 9.1.** Select and use a height reference (3D).
- **Workflow 9.2.** Select and use a side reference (3D).
- **Workflow 9.3.** Offset a model reference (3D).
- **Workflow 9.4.** Offset individual references (3D).

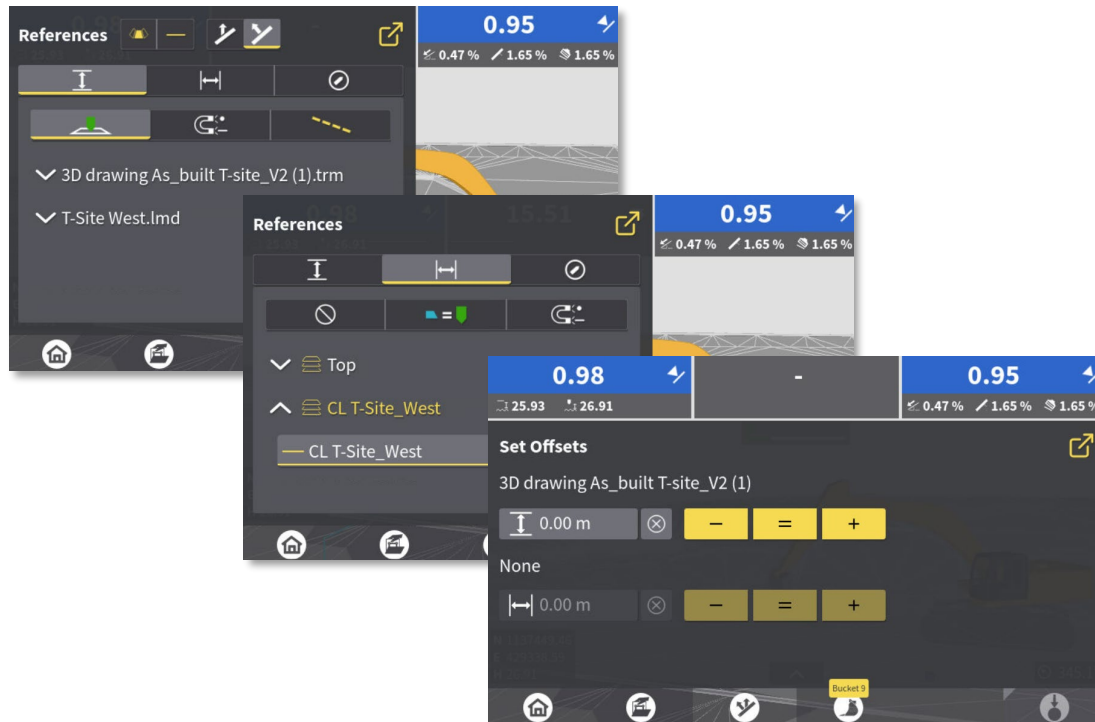

## Workflow 9.1. Select and use a height reference (3D)

From the run screen, you can select and use different parts of your model as height reference. The height tool point defines where MC1 looks at the model for elevation guidance. Understanding how this works is useful in different grading applications where you might need to overhang one part of your design to cut another. By default, cut/fill and slope values are based on the surface below current height tool point (middle height tool point shown in this workflow).



**Step 1:** Press and hold on plan view to see the "References" menu.

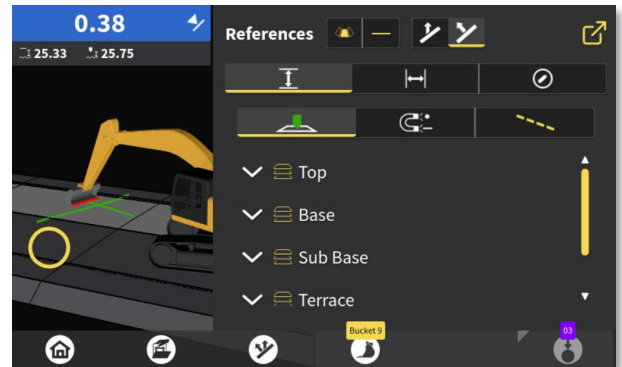

**Step 2:** Press height icon to view height references (if not already highlighted).

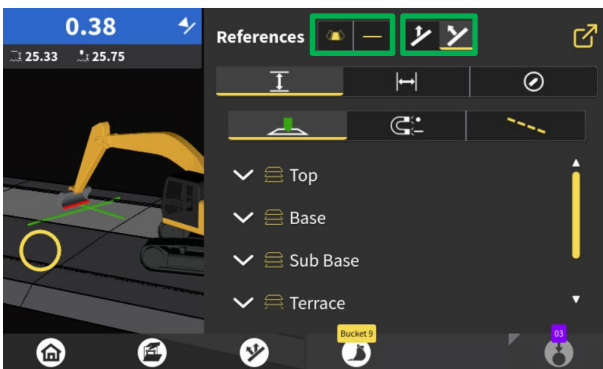

- It is possible to filter references (surfaces/lines) and to choose between a vertical or perpendicular height reference. Perpendicular reference mode is not applicable for semi-auto.

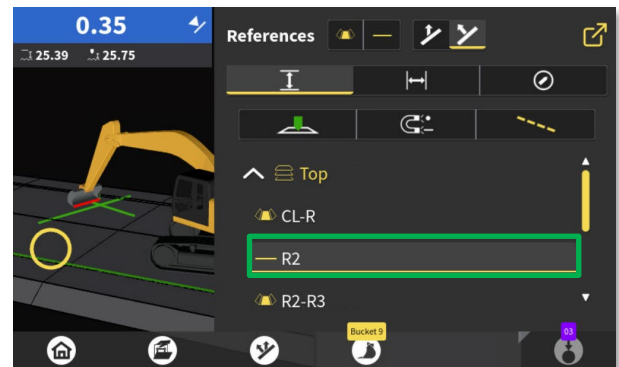

**Step 3:** Select the desired height reference.

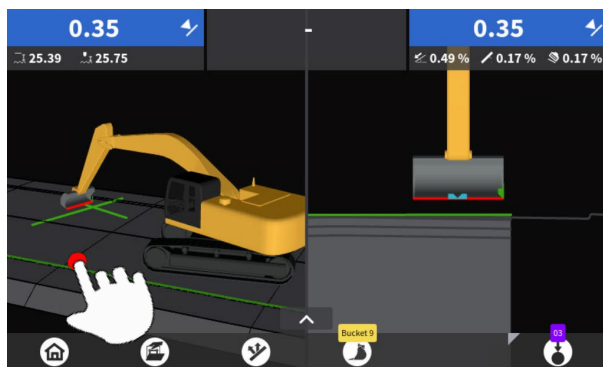

**Step 4:** Tap anywhere in the plan view to exit the "References" menu.



- The new surface will be represented by a bold green line. Cut/fill will be provided to this reference and design cross-slope and long slope will update to reflect the height reference selected.

## Workflow 9.2. Select and use a side reference (3D)

From the run screen, you can select and use different parts of your model as side reference. The side tool point defines where MC1 looks at the model for horizontal guidance. Select a point or line, and you will see a navigation bar at the top of the run screen. This navigation bar will guide you to the selected reference, based on your selected side tool point.



**Step 1:** Press and hold on plan view to see the "References" menu.

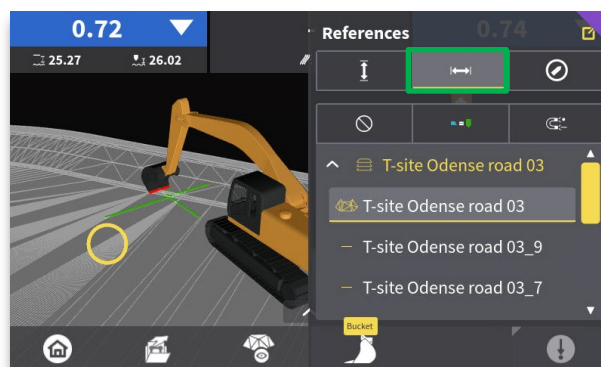

**Step 2:** Press  icon to view side references.

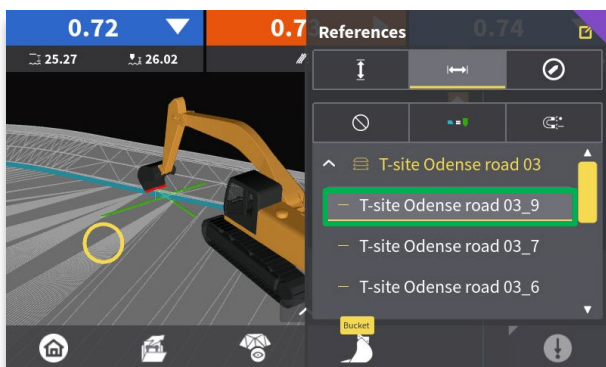

**Step 3:** Select desired line reference. The line closest to selected point is listed at the top.

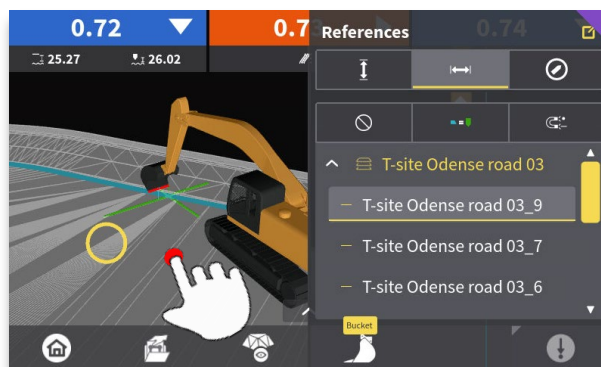

**Step 4:** Tap anywhere in the plan view to exit the "References" menu.

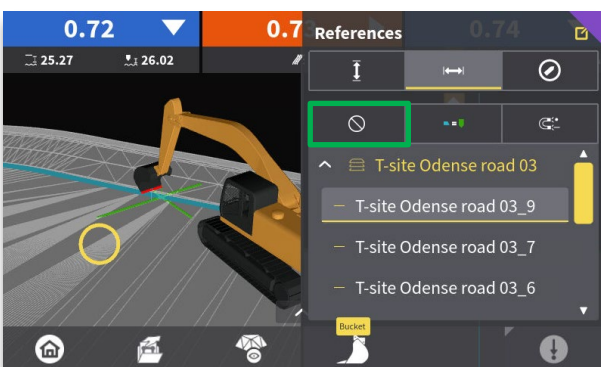

- The offset distance, from current side tool point to selected line reference, is shown at top centre of the screen. A teal line represents selected line in run screen.
- To clear the side reference, press and hold on run screen, press the side reference icon, then press the "None" icon to clear the side reference line.

## Workflow 9.3. Offset a model reference (3D)

When working outside of auto range limit, offsetting the model allows you to utilize automatics, and thus work more efficiently. Set height offset within auto range limit. As the surface is being worked, the cut/fill values will reduce to zero as the grade approaches design elevation. Height offsets are used in relation to the machine's height tool point.

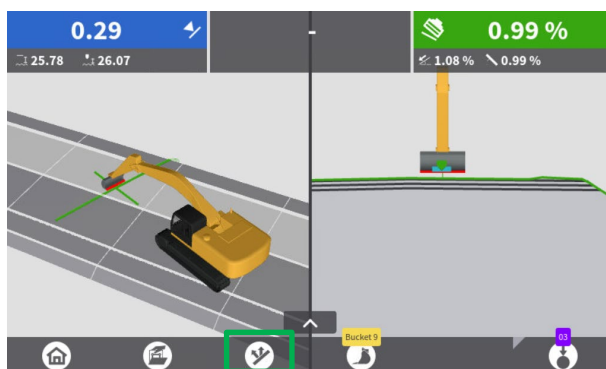

**Step 1:** Press the "Offsets" menu.

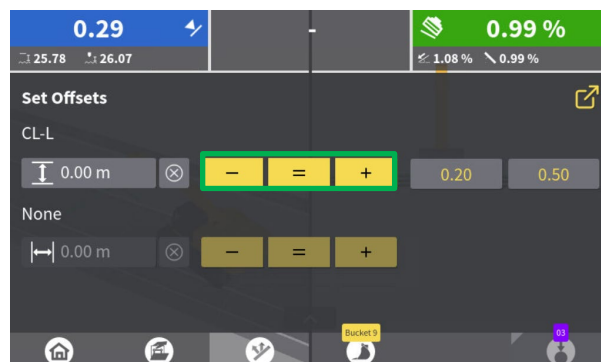

**Step 2:** Press - or + to offset your design by increments. Press = to set offset to current tool point height. Recently used offsets are available for quick selection.

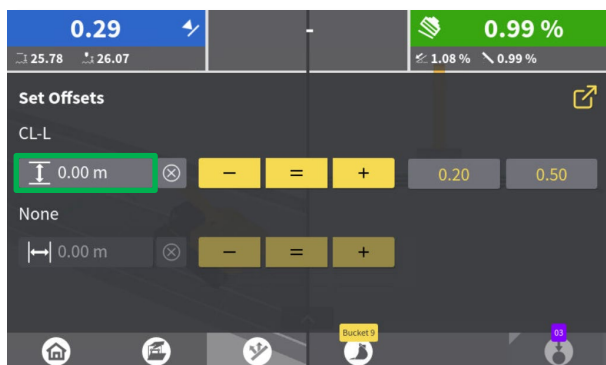

**Step 3:** Press the grey "Height offset" box for specific offset value input.

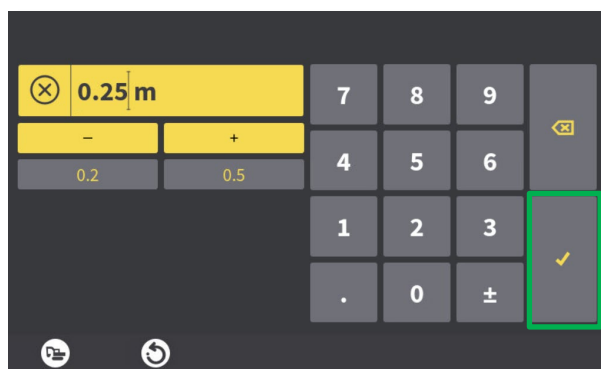

**Step 4:** Use keypad to input a value and toggle the sign. A list of the last offset values is available for quick selection. Press the tick mark icon to accept value.

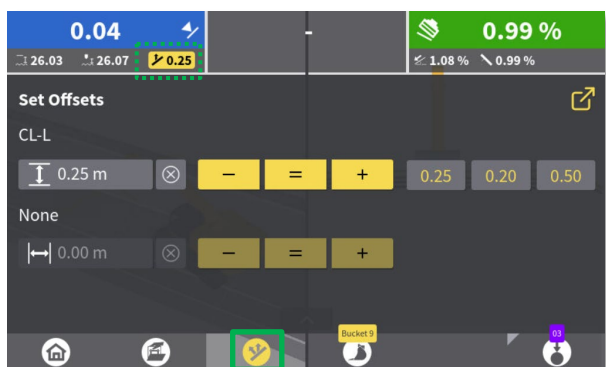

**Step 5:** The offset value will be shown as a small yellow box in the upper left corner and the offset icon will turn yellow to indicate an active offset. Press the offset menu icon to return to run screen.



- Cut/fill values will be shown, providing guidance to new height offset. Original grade will still be shown in cross-section with applied offset.

## Workflow 9.4. Offset individual references (3D)

In the expanded “Offsets” menu, you can offset individual references within a model. Only references and models eligible for height/side reference have the option to edit an offset value. Offsets are used in relation to the machine's tool point.



**Step 1:** Press the “Offsets” menu.

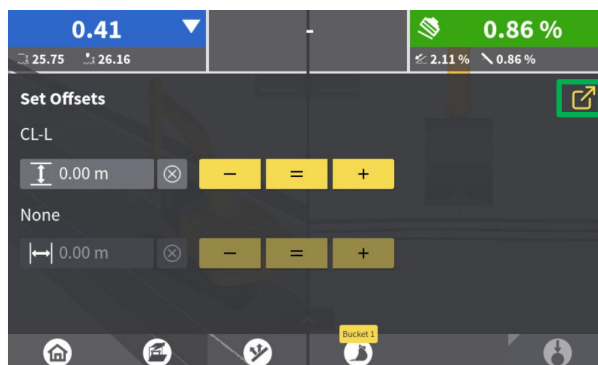

**Step 2:** Press the expansion button.

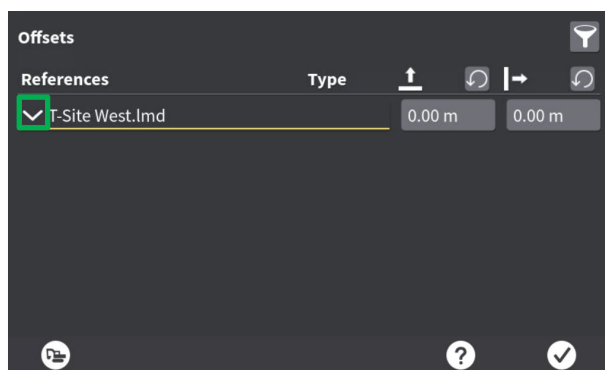

**Step 3:** Here you have a list of all the referential models. Press the expansion arrow and a height and/or side offset can be applied to individual references.

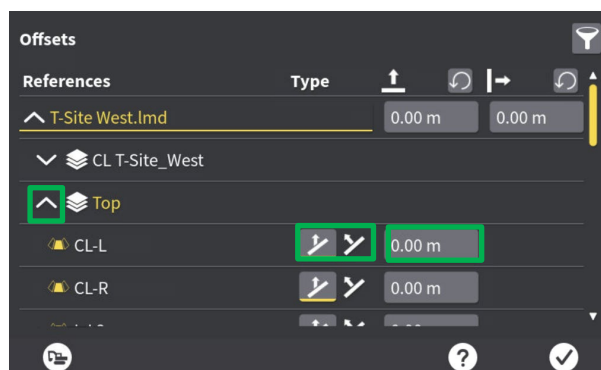

**Step 4:** Press the expansion arrow to fold out a reference. Toggle between the two offset icons to choose offset type. Press the grey box next to the offset icons to add an offset value.

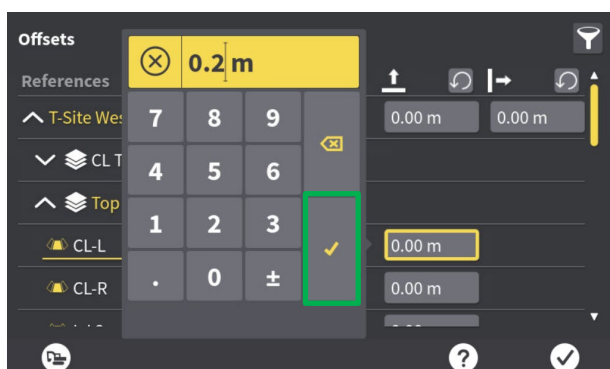

**Step 5:** Use the keypad to input a value and press tick mark to confirm.

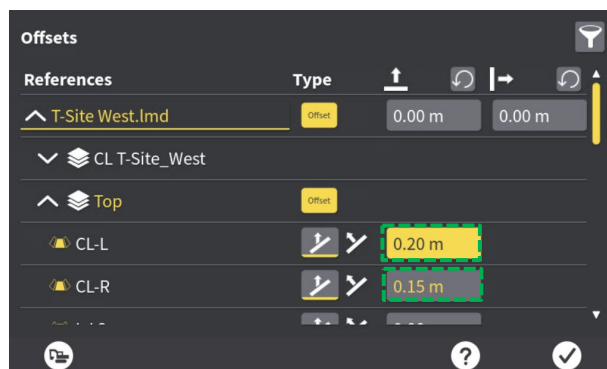

- The current active offset is highlighted in a yellow box, whereas other offsets are written in yellow text.

## Workflow 9.4. Offset individual references (3D), (Continued)

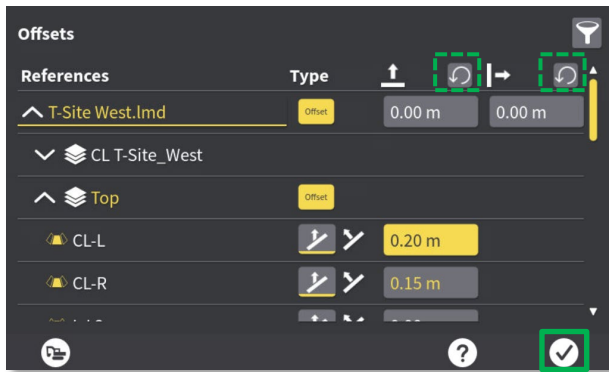

**Step 6:** The "revert" buttons at the top can be pressed to remove offset values for all references. Press tick mark icon to return to run screen.



- Cut/fill values will be shown, providing guidance to new height offset. Original grade will still be shown in cross-section with applied offset.

## 10. As-built

The following workflow focuses on as-built data:

- **Workflow 10.1.** Create point logs (3D).

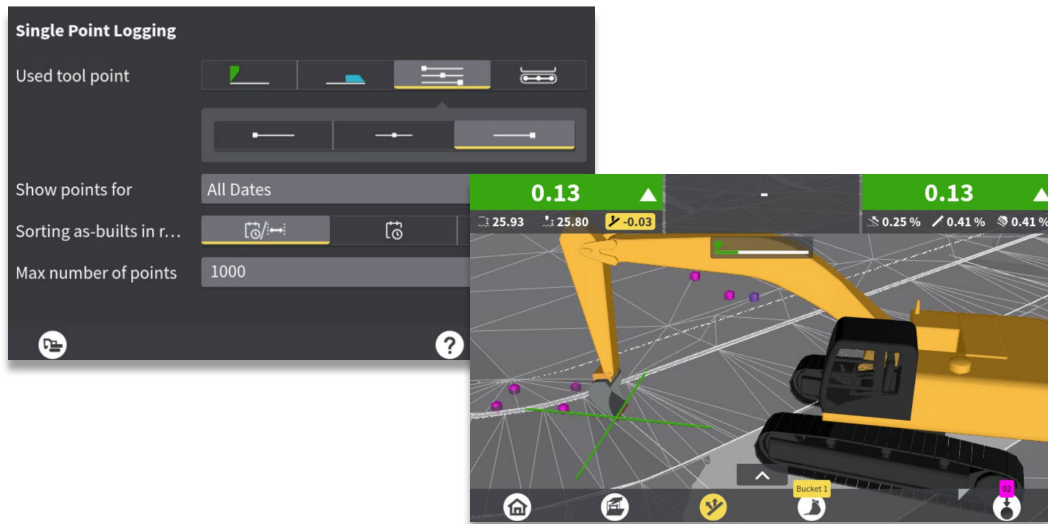

## Workflow 10.1. Create point logs (3D)

You can log points on your design, from the run screen. Apply a user defined point log, or select from a predefined point log. MC1 automatically sends stored points to ConX (if connected to ConX), including the model and height reference.

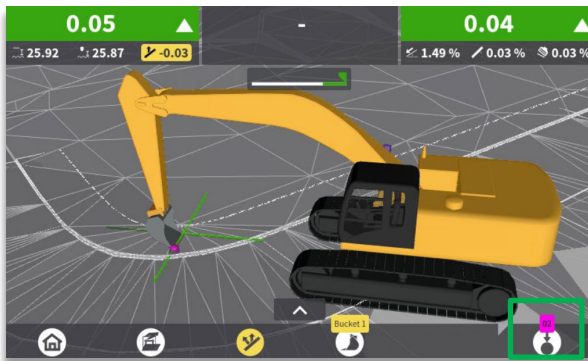

**Step 1:** Press the "log point" button to quickly log a point.

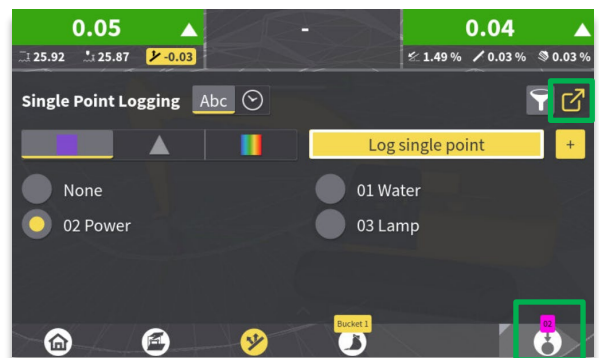

**Step 2:** Press and hold the "log point" button. Select a point code from available point code list and press the "log point" button to log a point with that point code. For more options press quick access button in top right corner.

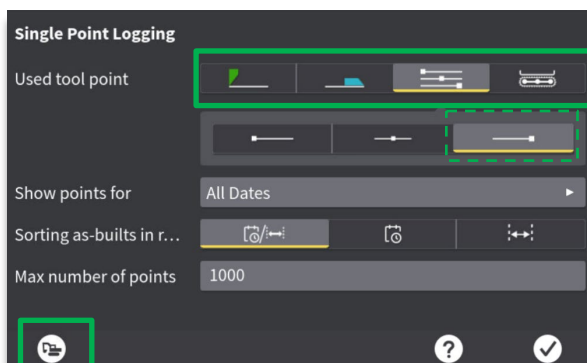

**Step 3:** Choose which tool point to use when logging a point (Current height tool point, current side tool point or specific tool point not used for height or side references). Press excavator icon to return to run screen.

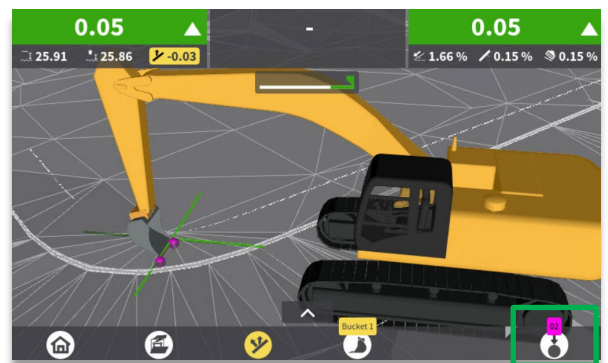

**Step 4:** Press the "log point" button to log a point. The label on top of the "log point" button will correspond the point code you have selected.



**Step 5:** If necessary, press "Revert" to remove previously logged point. You also have the option to add a comment to your point.



- If configured, previously stored points will appear in the plan view as coloured dots.

# 11. TPS

The following workflows focus on the use of total stations (TPS).

- **Workflow 11.1.** Set up your TPS (3D).
- **Workflow 11.2.** Confirm your machine control license (Captivate), (3D).
- **Workflow 11.3.** Confirm your machine control license (iCON Site), (3D).
- **Workflow 11.4.** Prepare your TPS for connection to MC1 (3D).
- **Workflow 11.5.** Connect your TPS to MC1 (3D).
- **Workflow 11.6.** Work with a single TPS (3D).
- **Workflow 11.7.** Work with dual TPS (3D).
- **Workflow 11.8.** Use prism search to re-connect a TPS (3D).
- **Workflow 11.9.** Perform daily check-in (TPS), (3D).
- **Workflow 11.10.** View machine position (Captivate), (3D).
- **Workflow 11.11.** View machine position (iCON Site), (3D).

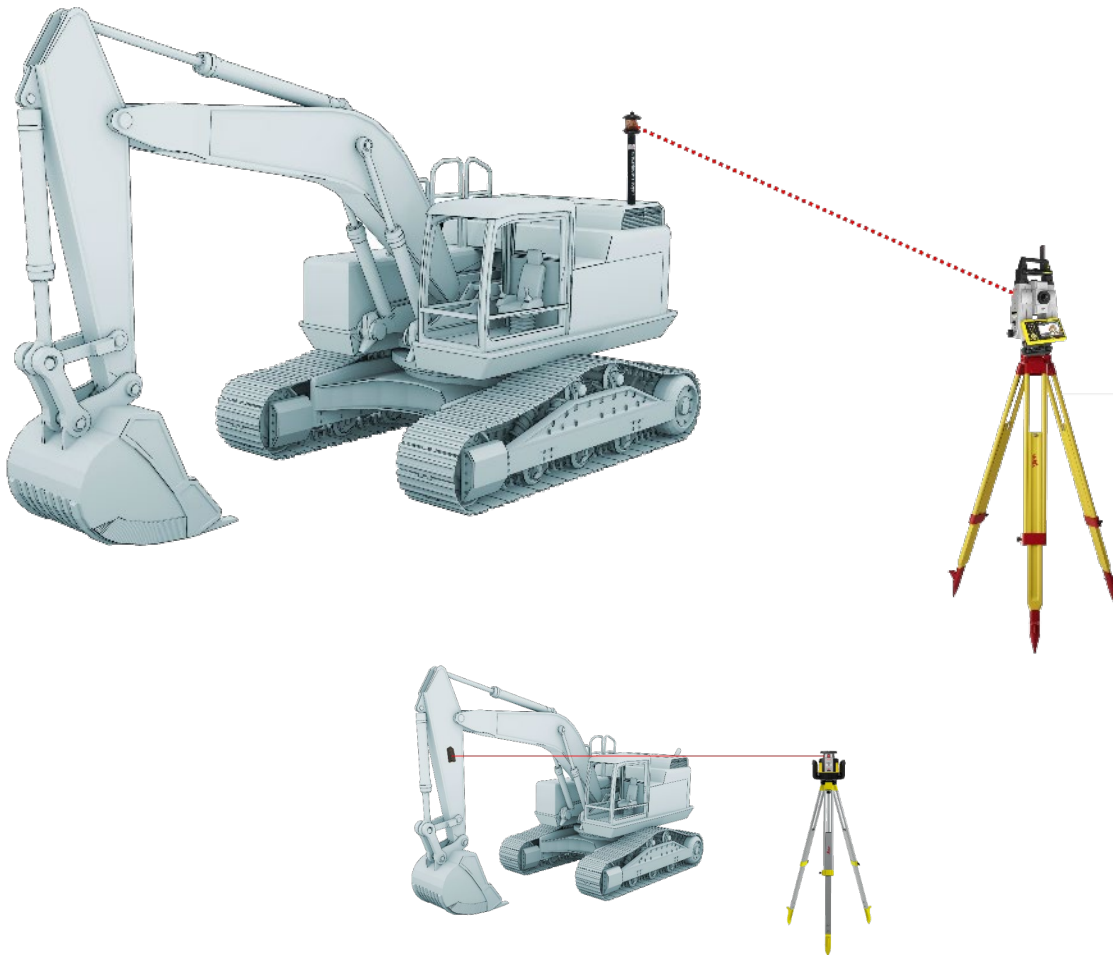

## Workflow 11.1. Set up your TPS (3D)

When setting up a total station (TPS) there are a few things you should think about. You need to place your TPS in a way that gives you a good oversight over the area you are working on. You need a clear line of sight from TPS to the prism on your machine.

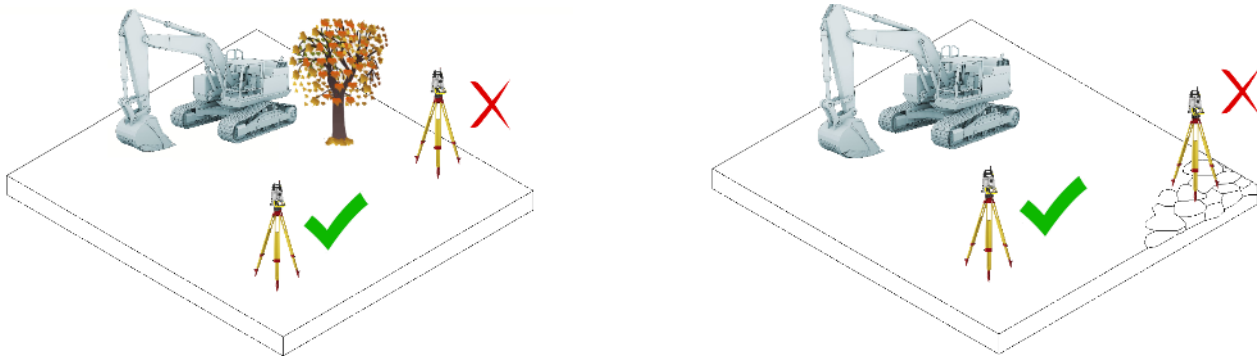

**Step 1:** Choose a good location for your TPS setup:

- Make sure you have a clear line of sight between TPS and machine prism.
- Pace the tripod on stable ground, so it won't shift or settle.

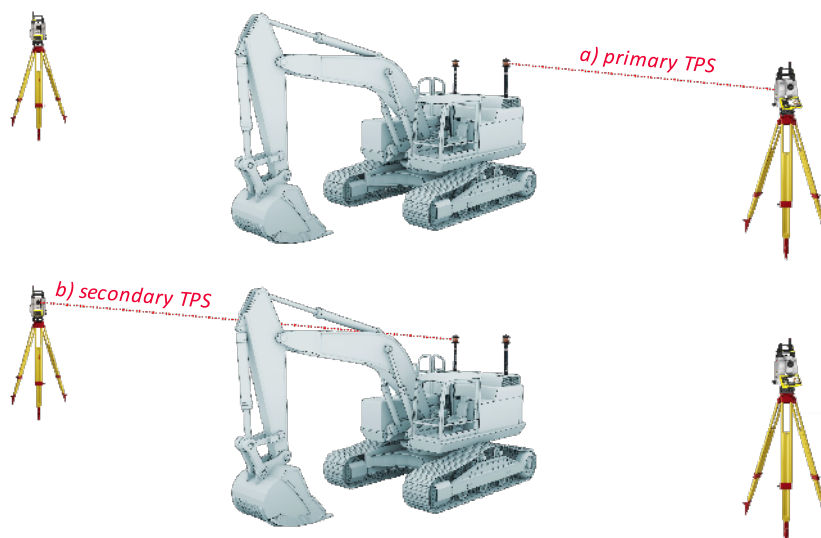

- Place your total station on the same side of the machine as the prism you are going to lock onto **a)** left side = primary TPS **b)** right side = secondary TPS. That way you minimize the risk of obstructing line of sight with for example railings or exhaust pipe (exhaust fumes may distort the view between prism and TPS).



**Step 2:** Check tripod, attach your TPS and aim:

- Make sure all tripod screws, bolts and nuts are tight.
- Place TPS on tripod and tighten screw on underside to secure it to the tripod.
- If your tripod has chains, those chains should be slightly loose to allow for thermal expansion during the day.
- Setup your total station with the setup pilot.
- **Aim your total station to the desired machine prism.**

## Workflow 11.2. Confirm your machine control license (Captive), (3D)

Your 3D machine control solution allows connection between the TPS and MC1. In this workflow you will learn how to confirm that you have a license loaded in the **Captive** software application.

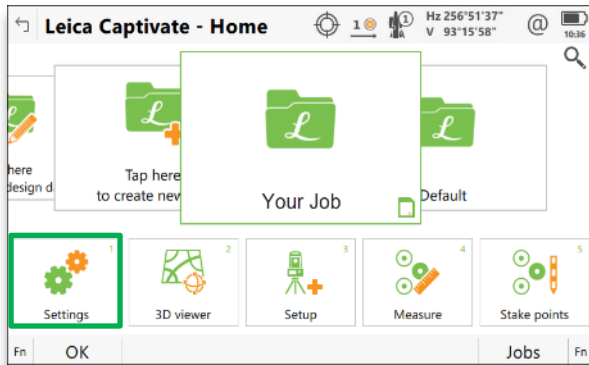

**Step 1:** Press the "Settings" menu.

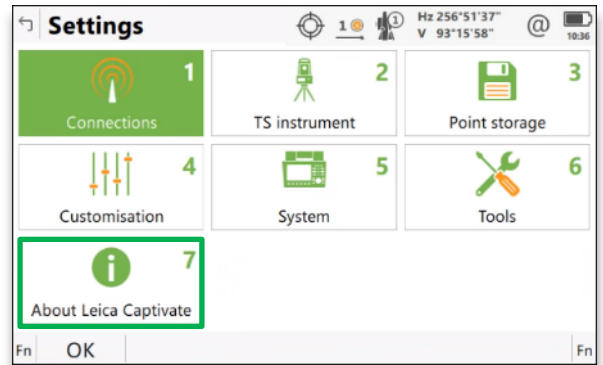

**Step 2:** Press the "About Leica Captivate" menu.



**Step 3:** Press the "Leica Captivate" tab.



**Step 4:** Scroll the page upward until you see "Machine Control App". Verify that a license has been loaded.

## Workflow 11.3. Confirm your machine control license (iCON Site), (3D)

Your 3D machine control solution allows connection between the TPS and MC1. In this workflow you will learn how to confirm that you have a valid license loaded in the iCON Site software application.

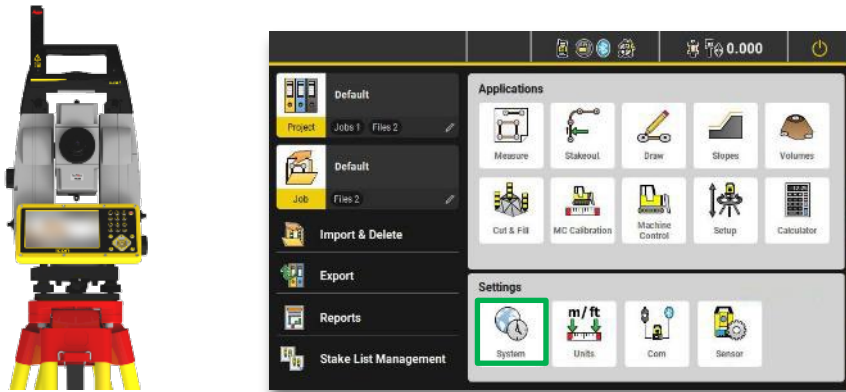

**Step 1:** Press the “System” menu.

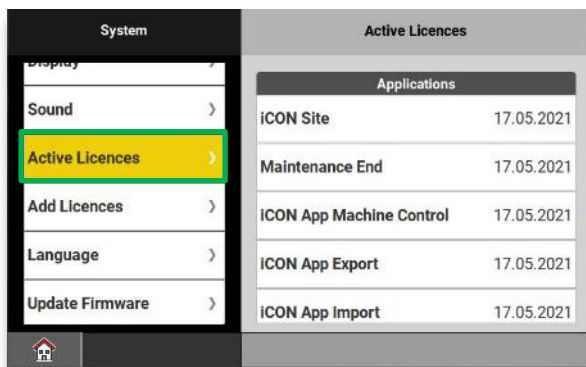

**Step 2:** Press the “Active Licences” menu.

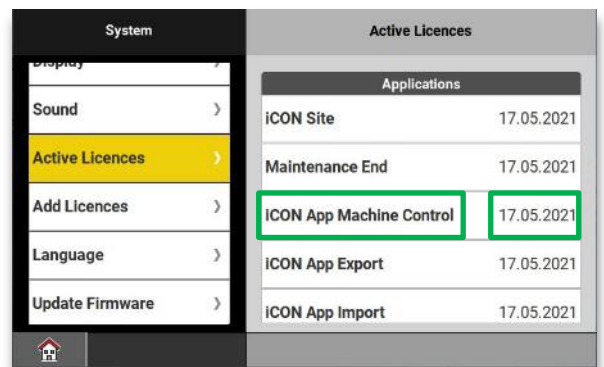

**Step 3:** Verify that the “iCON App Machine Control” license is loaded with a valid date.

## Workflow 11.4. Prepare your TPS for connection to MC1 (3D)

When you've chosen a location for your TPS and performed the TPS setup it's time to put the TPS in machine control mode.

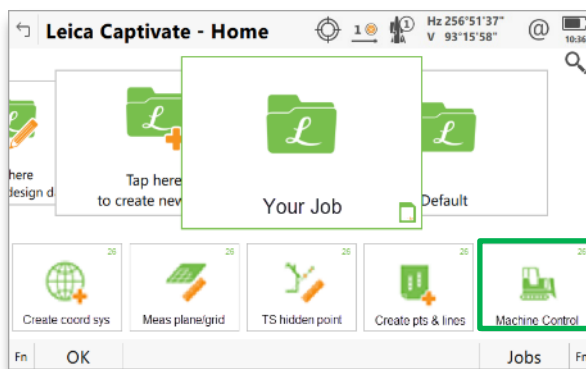

**Step 1:** If you use **Captivate**, then manually launch the "Machine Control" app.

### NOTE:



- If you use **iCON Site**, you don't need to enter a machine control mode. The "Machine Control" app is launched automatically by MC1.

## Workflow 11.5. Connect your TPS to MC1 (3D)

In this workflow you will learn how to connect your TPS to MC1.

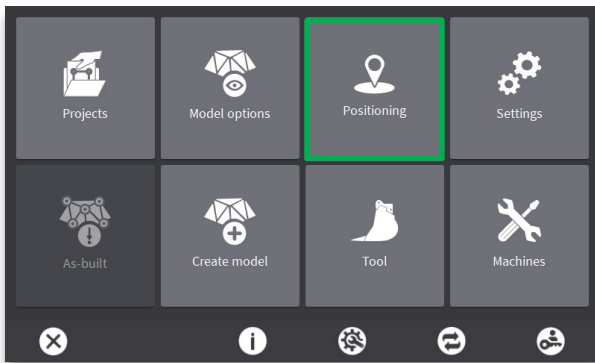

**Step 1:** Press the "Positioning" menu.

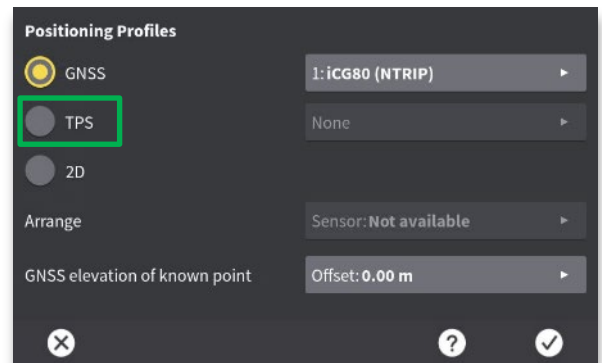

**Step 2:** Select "TPS".

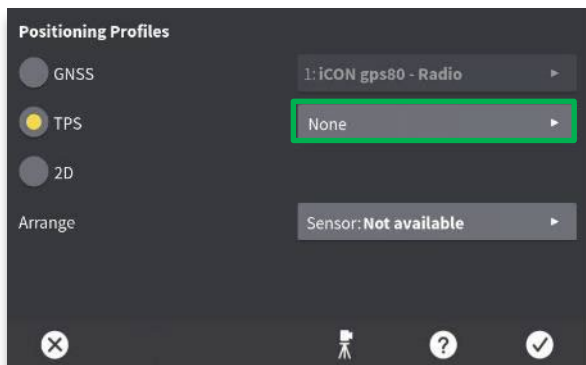

**Step 3:** Press the "TPS" menu.

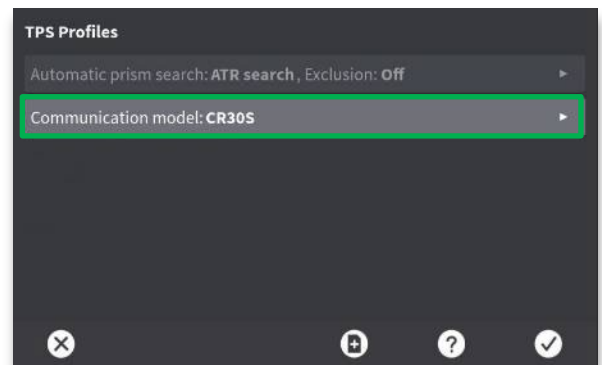

**Step 4:** Press the "Communication model" menu, and select the desired model.

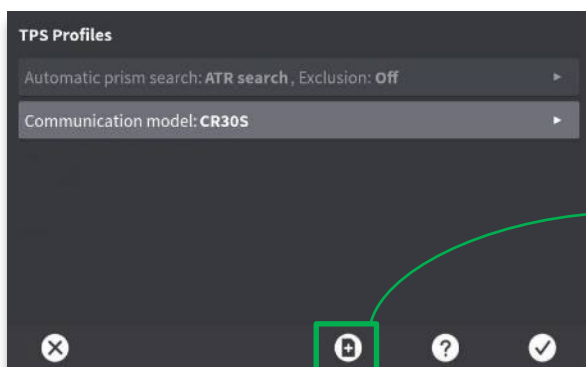

**Step 5:** Press the "new profile" button.

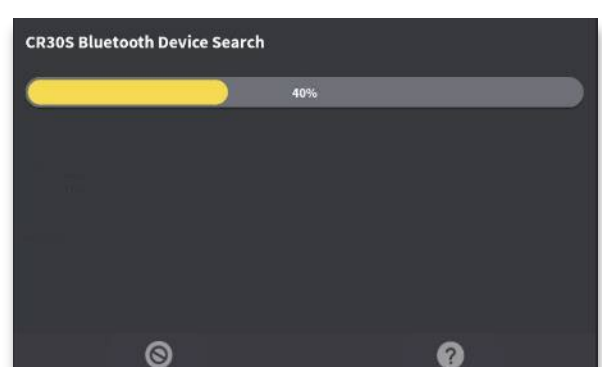

- The modem now automatically searches for nearby TPS devices.

## Workflow 11.5. Connect your TPS to MC1 (3D), (Continued)

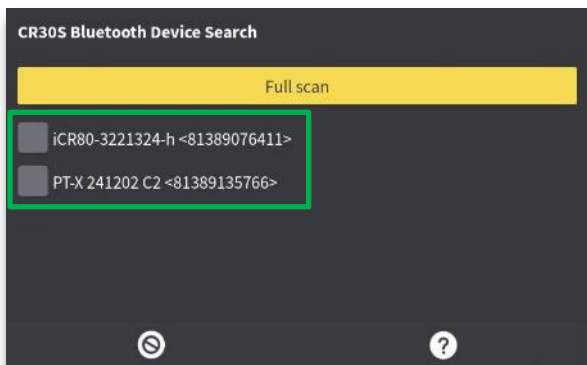

**Step 6:** Nearby TPS devices are listed. Select the devices you want to use for machine control.

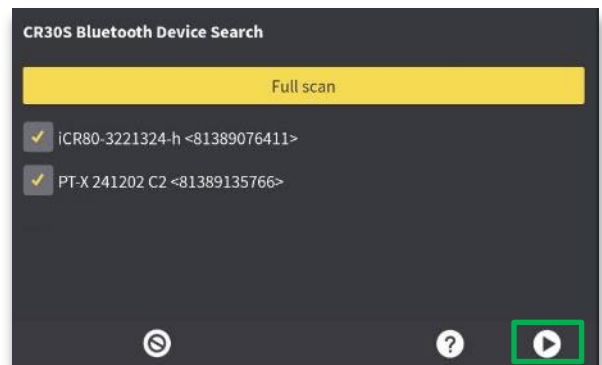

**Step 7:** Press right arrow (OK).

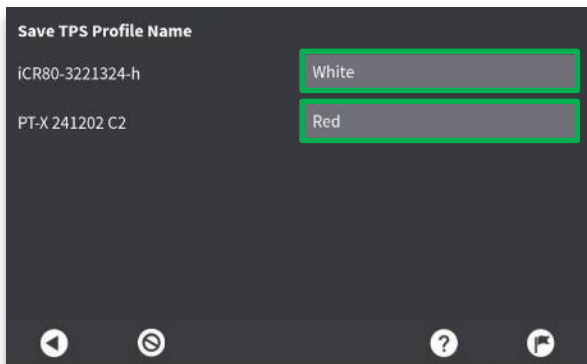

**Step 8:** Name your TPS profiles (recommended for dual TPS). Press flag icon (finish).

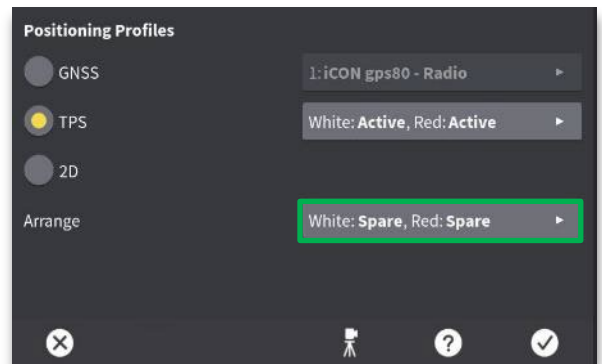

**Step 9:** Press the "Arrange" menu.

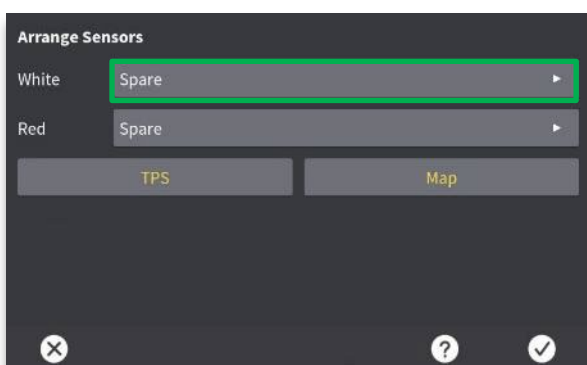

**Step 10:** Press the menu next to the TPS you want to assign a role to.

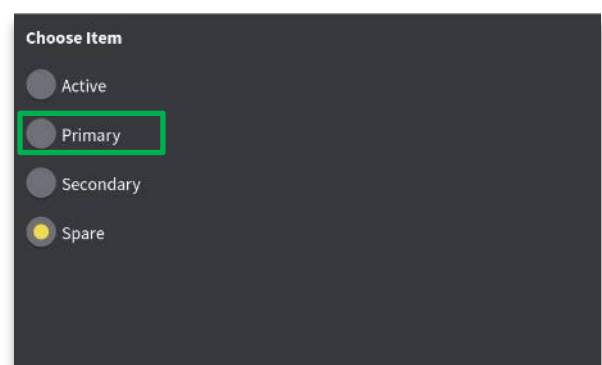

**Step 11:** Select the role you want to assign to your TPS (matching your setup).

## Workflow 11.5. Connect your TPS to MC1 (3D), (Continued)

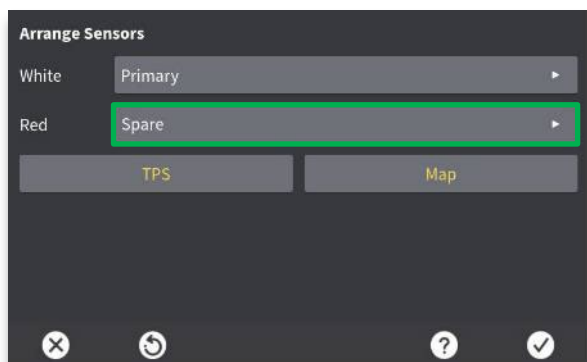

**Step 12:** Assign roles to remaining TPS devices. Press tick mark icon (OK).

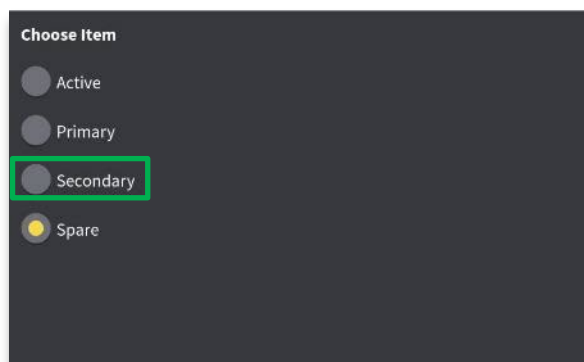

**Step 13:** Select the desired role.



**Step 14:** Press tick mark icon (OK).

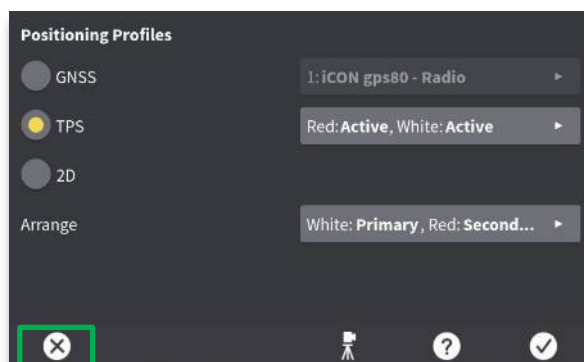

**Step 15:** Press X (exit).

## Workflow 11.6. Work with a single TPS (3D)

When you've connected your TPS to MC1 it's time to start working. To get the bucket position when using single TPS, we need to rotate the machine to estimate heading. This heading must be re-established whenever the machine has shifted, or is tracked to a new position. Machine rotation is not necessary when using dual TPS ([Workflow 11.7.](#)).

Prior to using a TPS, the prism on your machine must be installed and calibrated by a certified installer.

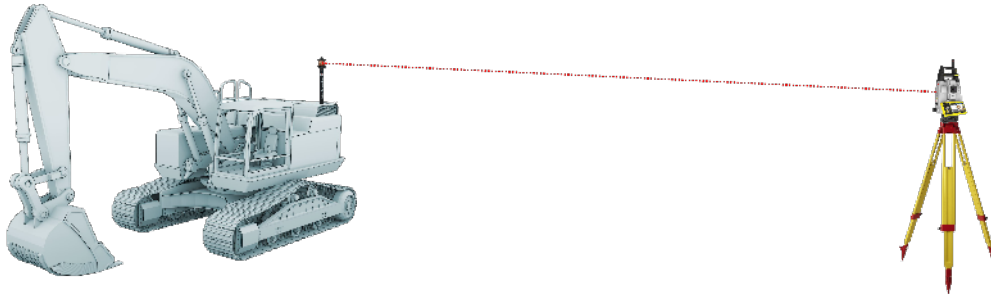

**Step 1:** Aim the TPS at the prism.



**Step 2:** The TPS now locks onto the prism and a rotation graphic appears.

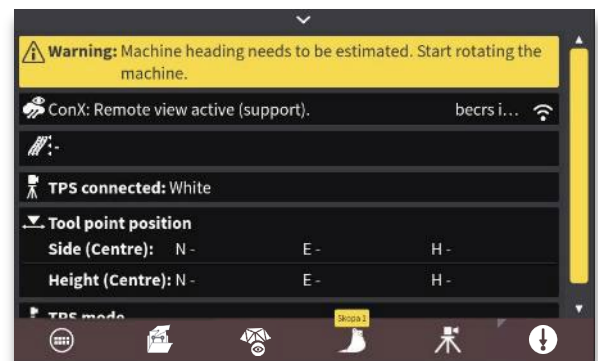

- An info bar prompts you to rotate the machine.

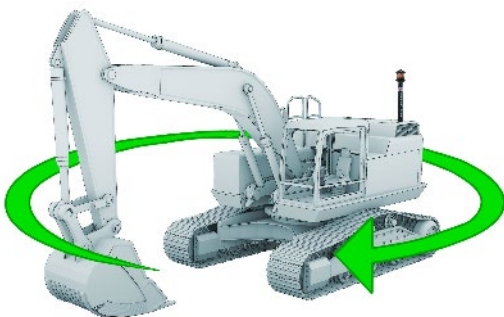

**Step 3:** Rotate the machine to estimate the correct heading.



- The MC1 run screen displays the rotation progress.

## Workflow 11.6. Work with a single TPS (3D), (Continued)

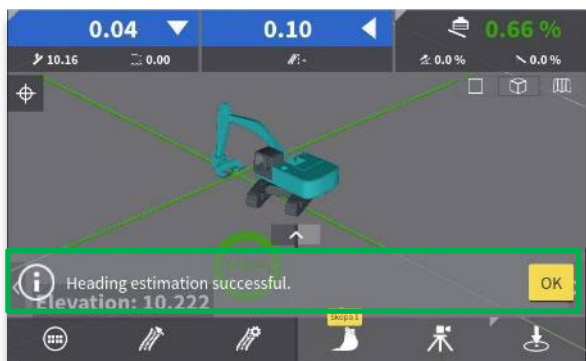

- Upon successful rotation, a confirmation message appears.

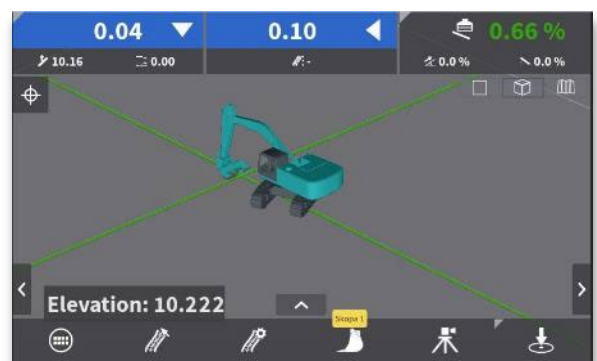

- The machine is ready to begin working.

## Workflow 11.7. Work with dual TPS (3D)

When you've connected your TPS devices to MC1 it's time to start working.

When using dual TPS it is not necessary to rotate the machine to estimate the machine heading, like with single TPS. But you should take care not to switch prism connection when you do have to rotate the machine.

Prior to using TPS devices, the prisms on your machine must be installed and calibrated by a certified installer.

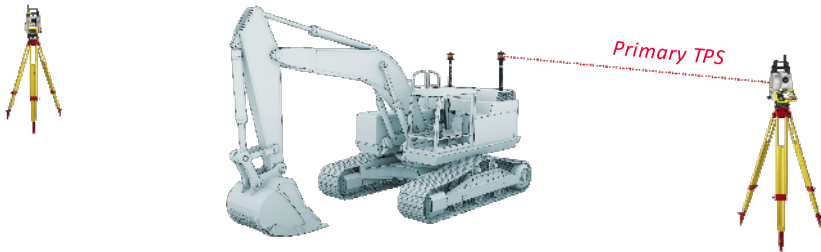

**Step 1:** Aim the "primary" TPS to the left side prism.

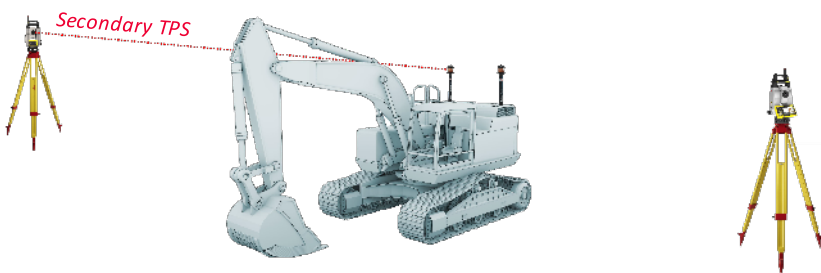

**Step 2:** Aim the "secondary" TPS to the right side prism.

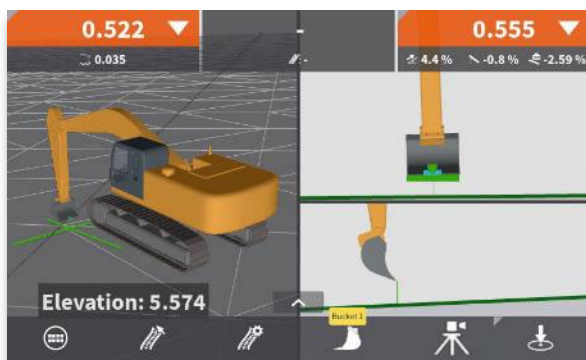

- The machine is ready to begin working.

## Workflow 11.8. Use prism search to re-connect a TPS (3D)

When an obstacle blocks the line of sight between TPS and machine prism, the TPS loose connection to MC1.

The TPS is often able to re-connect by itself if the machine prism stays in the same general area. But, if the TPS does not re-connect automatically, you must perform a prism search to re-connect.

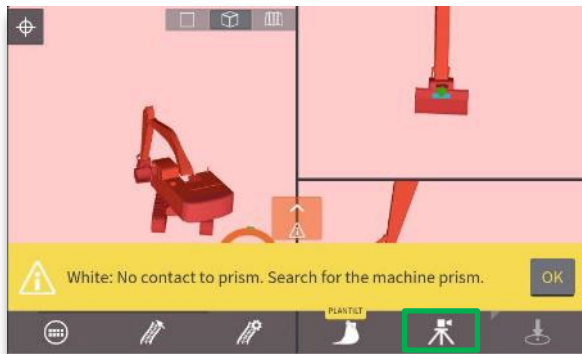

**Step 1:** If prism lock is lost, plan view turns red. A warning message appears. Press the TPS icon.

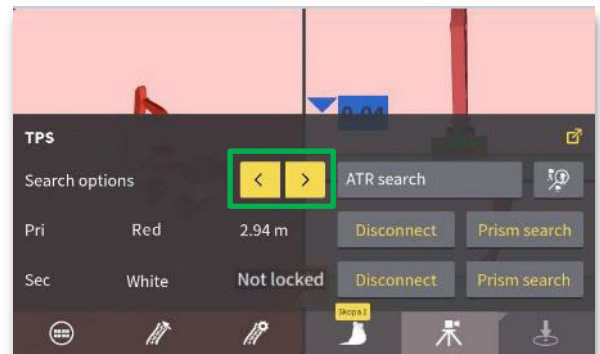

**Step 2:** Press <> to cycle through prism search modes until you see "ATR search".

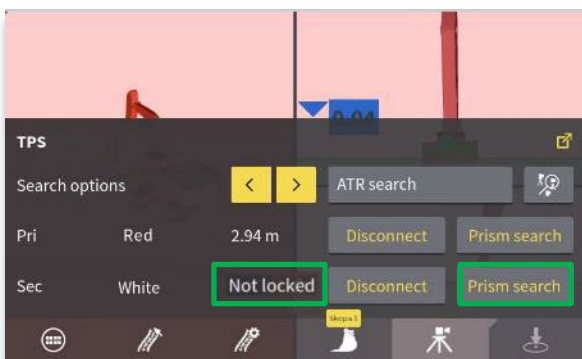

**Step 3:** Press "Prism search" next to the TPS where "Not locked" is displayed.

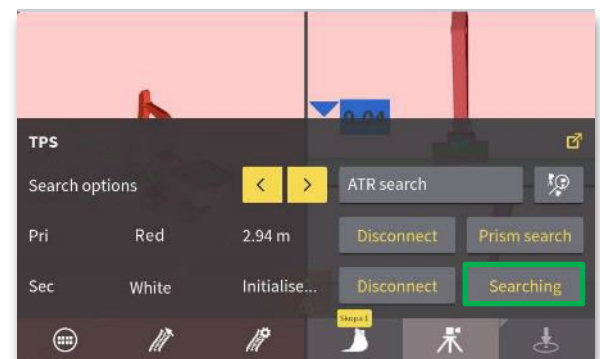

- The system searches for the lost prism.

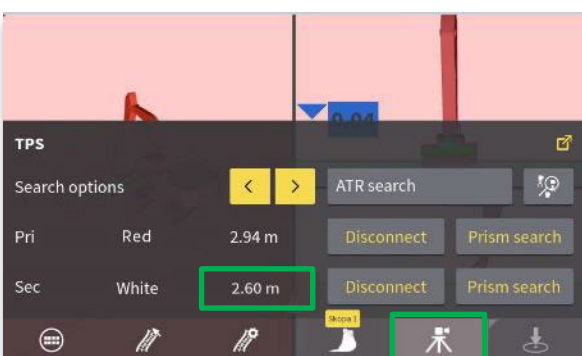

**Step 4:** When found, the distance between prism and TPS is displayed. Press the TPS icon to close the menu.



- The system is now ready to work again.

## Workflow 11.9. Perform daily machine check-in (TPS), (3D)

An ideal control point, to use for machine check-in, is positioned in an area that will not be disturbed for the duration of the project.

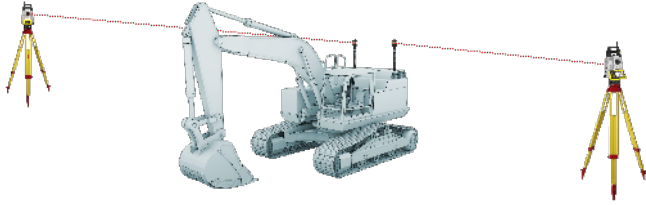

**Step 1:** Connect TPS devices to MC1 ([Workflow 11.5](#)).

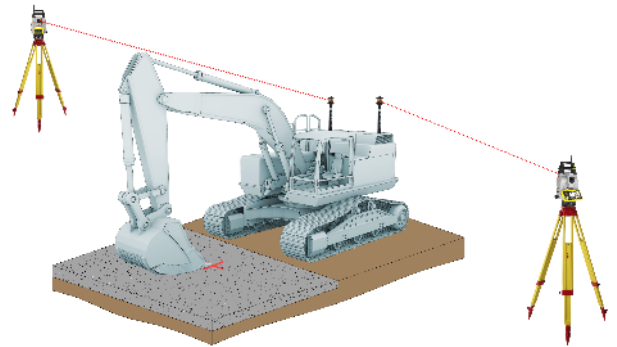

**Step 2:** Position desired tool point at control point.



**Step 3:** Use “up/down” and “left/right” keys to place both “height” and “side” tool points at the control point position.



**Step 4:** Open the “iCON info bar”.

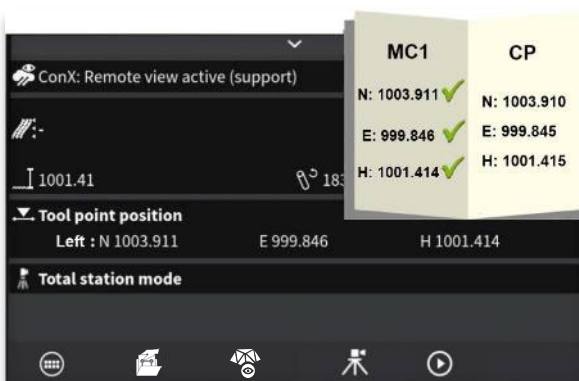

**Step 5:** Compare tool point position to control point (CP) coordinates. If your elevation offset is more than 10cm (.328 feet), please call your machine technician for assistance.

## Workflow 11.10. View machine position (Captive), (3D)

If a TPS running **Captive** is connected to your machine, you are able to view the machine position in the tracking menu.

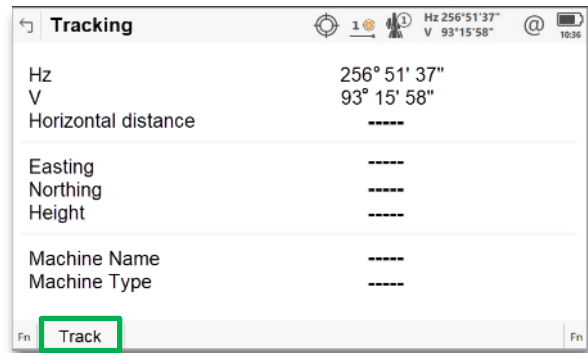
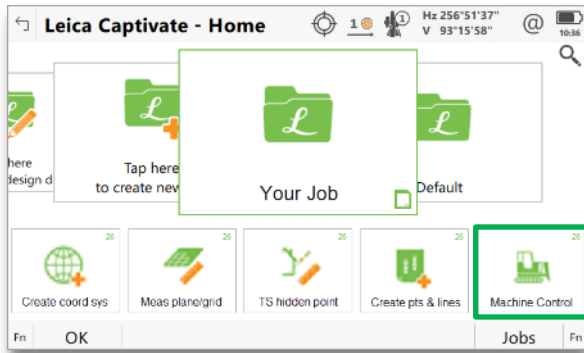

**Step 1:** When your total station is set up, enter the “Machine Control” app. Make sure it is installed, and that you have the corresponding license ([Workflow 11.4.](#)).

**Step 2:** Press the "Track" button.

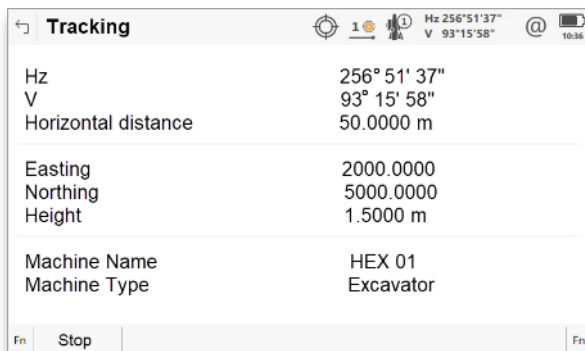

**Step 3:** View position of the prism being tracked, and information about the connected machine.

## Workflow 11.11. View machine position (iCON Site), (3D)

If a TPS running iCON Site is connected to your machine, the "Machine Control" application shows the tracked machine on the map. The info bar also provides relevant position information.

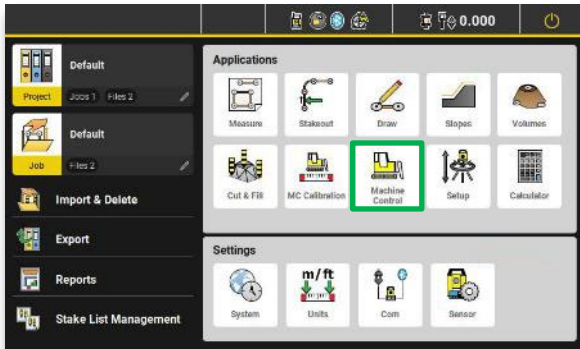

**Step 1:** Press the "Machine Control" application.

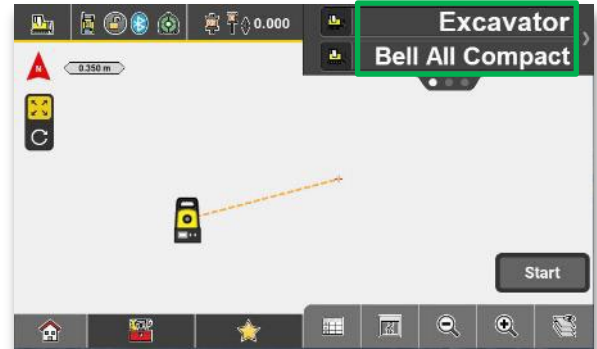

- The machine name and model will be shown in the first page of the info panel.

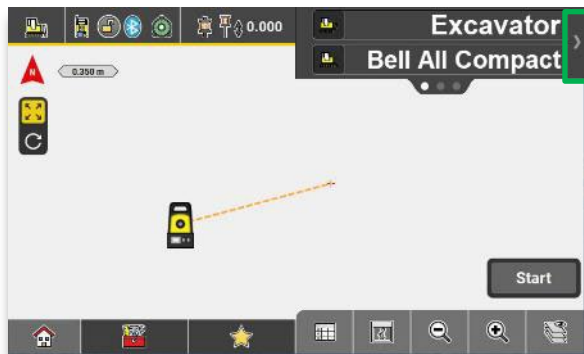

**Step 2:** Press the > icon.

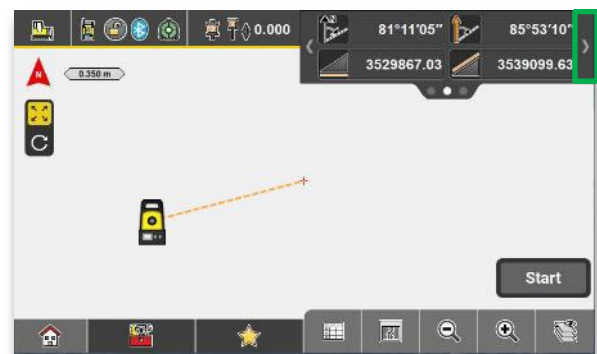

**Step 3:** Press the > icon again.

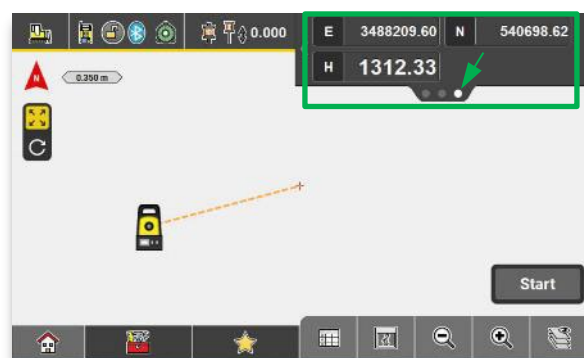

- The coordinates of the tracked machine will be shown in page three of the info panel.

## 12. GNSS

The following workflows focus on the use of GNSS:

- **Workflow 12.1.** Select GNSS positioning profile (3D).
- **Workflow 12.2.** Perform daily machine check-in (GNSS), (3D).
- **Workflow 12.3.** Perform "GNSS elevation of known point" (3D).

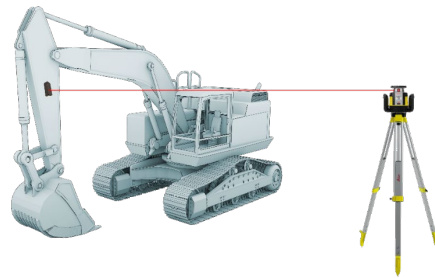
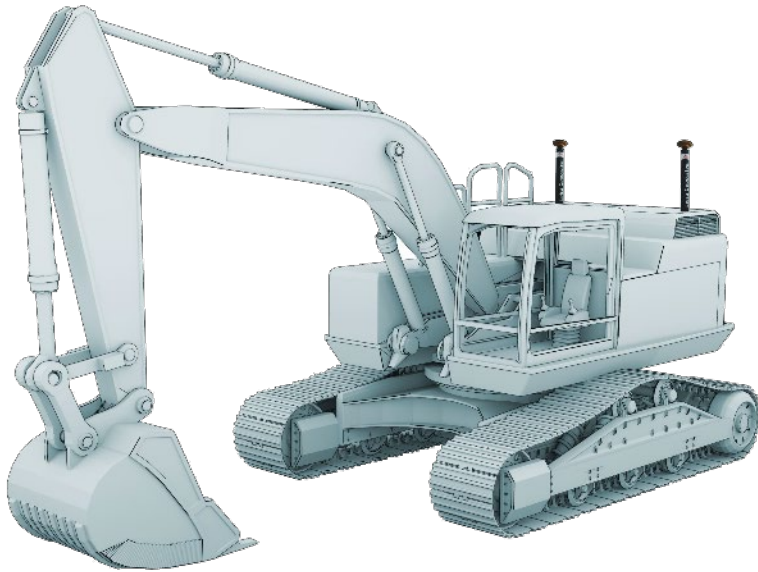

## Workflow 12.1. Select GNSS positioning profile (3D)

With the installer login multiple positioning profiles can be created and saved in MC1 to allow quick transitions between correction types. You as an operator can then choose between previously saved positioning profiles.

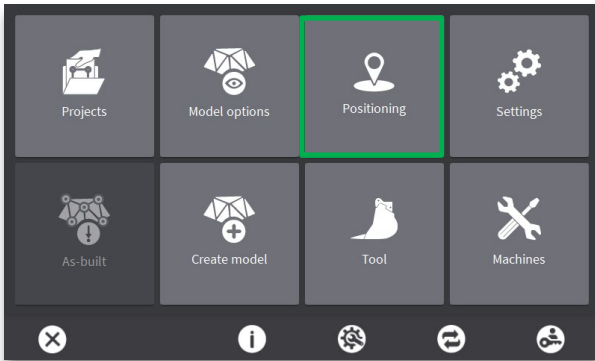

**Step 1:** Press the "Positioning" menu.

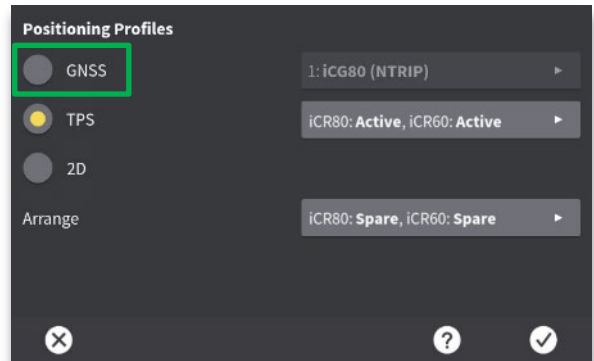

**Step 2:** Select GNSS.

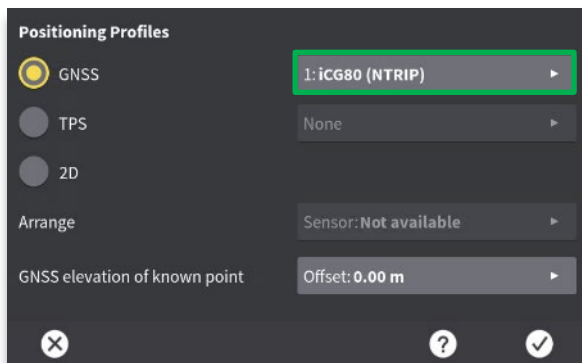

**Step 3:** Press the "GNSS" menu.

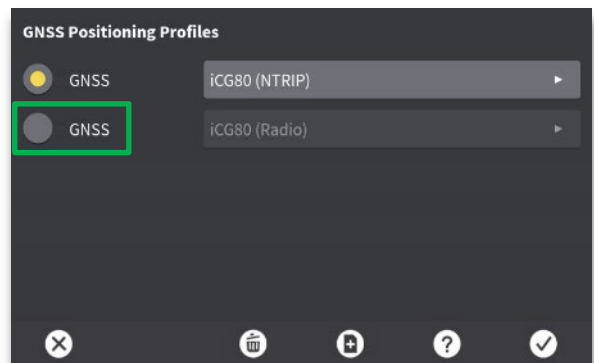

**Step 4:** Select desired positioning profile. Press tick mark icon (OK).

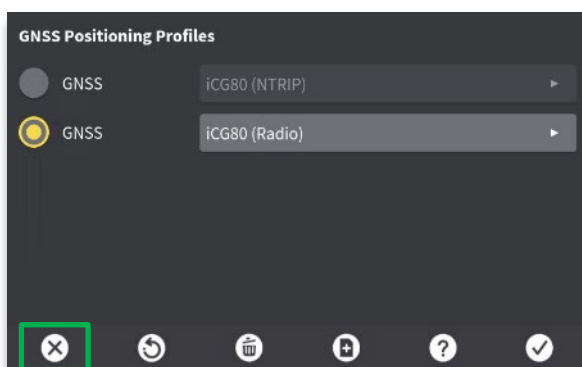

**Step 5:** Press X to apply changes and return to run-screen.

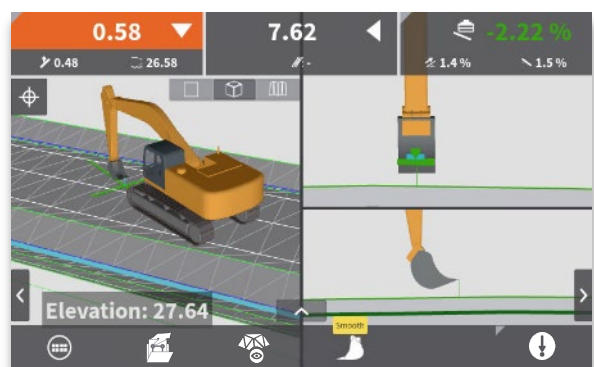

- Selected positioning profile is applied.

## Workflow 12.2. Perform daily machine check-in (GNSS), (3D)

An ideal control point, to use for machine check-in, is positioned in an area that will not be disturbed for the duration of the project. The location should allow for the machine and cutting edge of bucket to be level in cross slope. It is recommended to use a spotter on the ground to position the blade precisely.

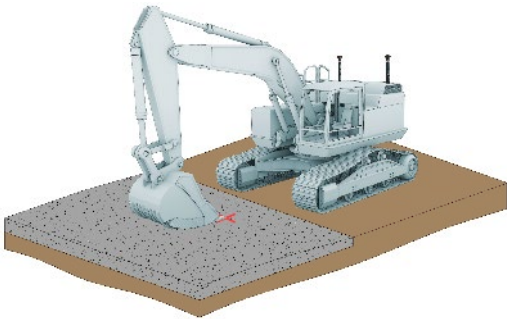

**Step 1:** Position desired tool point at control Point.



**Step 2:** Use “up/down” and “left/right” keys to place both “height” and “side” tool points at the control point position.



**Step 3:** Open the “iCON” info bar.

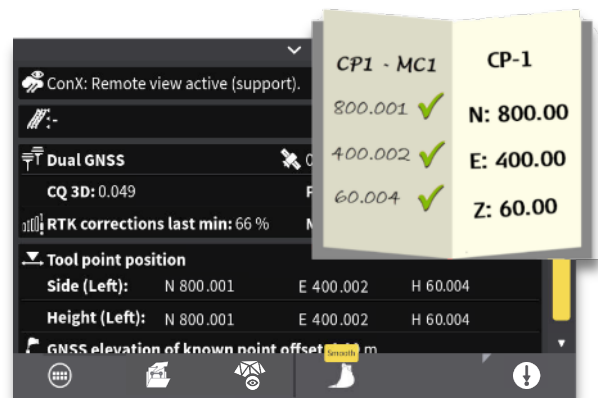

**Step 4:** Compare tool point position to control point (CP) coordinates. If your elevation offset is more than 10cm (.328 feet), please call your machine technician for assistance.

## Workflow 12.3. Perform "GNSS elevation of known point" (3D)

When working with GNSS as a correction source MC1 allows you to adjust the machine height after checking in on a known point.

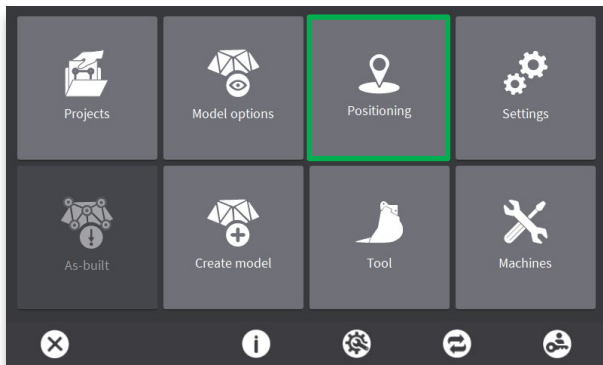

**Step 1:** Press the "Positioning" menu.

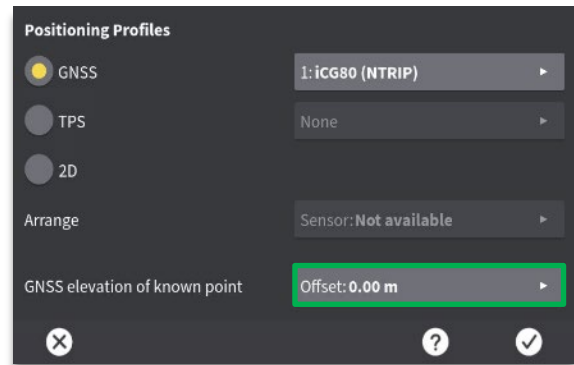

**Step 2:** Press the "GNSS elevation of known point" menu.

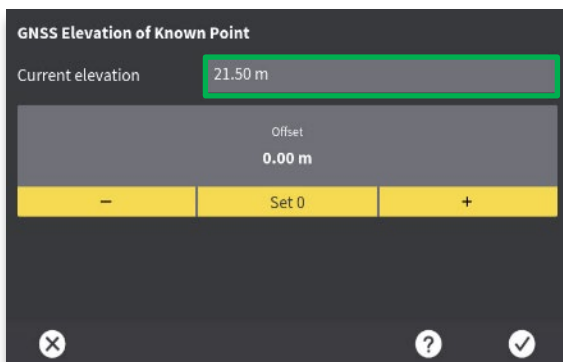

**Step 3:** Press the window next to "Current elevation".

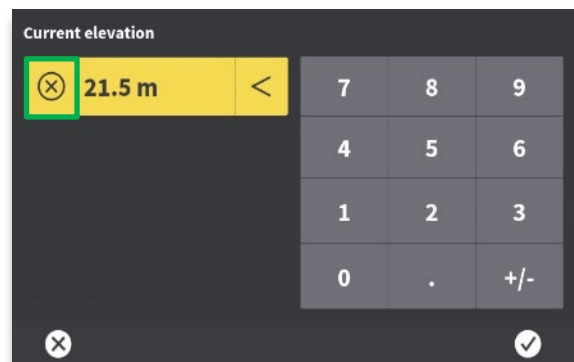

**Step 4:** Press X (next to the height value) to delete the current height.

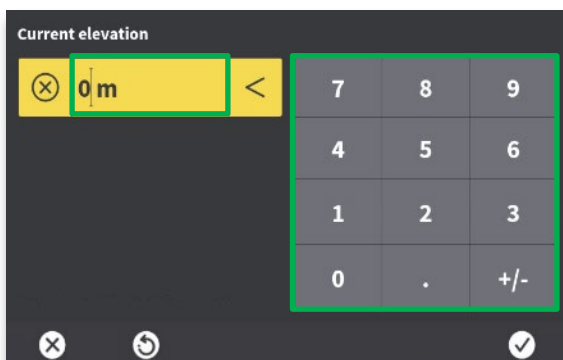

**Step 5:** Enter the elevation of current control point (CP). Press tick mark icon (OK).

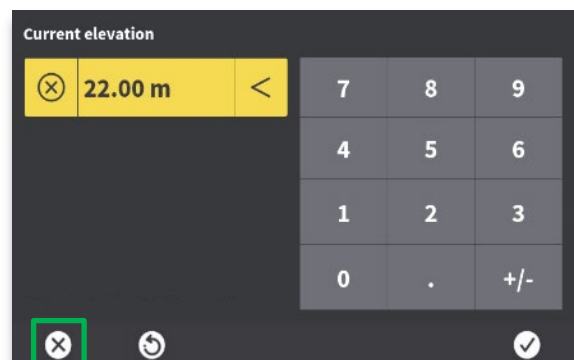

**Step 6:** Press X (exit) to apply height value and return to run-screen.